



SUNNICA ENERGY FARM

EN010106

Volume 6

Environmental Statement

6.2 Appendix 13C: Framework Construction Traffic Management
Plan and Travel Plan

APFP Regulation 5(2)(a)

Planning Act 2008

Infrastructure Planning (Applications: Prescribed Forms and
Procedure) Regulations 2009



3 March 2023
Version number: 05

Planning Act 2008

**The Infrastructure Planning
(Applications: Prescribed Forms and
Procedure) Regulations 2009**

Sunnica Energy Farm

**Environmental Statement
Appendix 13C: Framework Construction Traffic Management Plan and
Travel Plan**

Regulation Reference:	Regulation 5(2)(a)
Planning Inspectorate Scheme Reference	EN010106
Application Document Reference	EN010106/APP/6.2
Author	Sunnica Energy Farm Project Team

Version	Date	Status of Version
Rev 00	18 November 2021	Application Version
Rev 01	30 August 2022	Change Report
Rev 02	22 November 2022	Deadline 3: Update based on examination questions and Local Impact Report
Rev 03	28 November 2022	Deadline 3A: Update based on examination questions and Local Impact Report
Rev 04	13 January 2023	Change Report 2
Rev 05	03 March 2023	Deadline 7: Update based on examination questions

Table of contents

Chapter	Pages
1 Introduction	1
1.1 Background	1
1.2 Scope	3
1.3 Scheme Updates	3
1.4 Update to this Document	6
1.5 Objectives	7
1.6 Report Structure	7
2 Construction Movements	8
2.1 Introduction	8
2.2 Construction Period	8
2.3 Construction Movements	8
2.4 Staff Movements	13
3 Local Authority Freight Management Plans	16
3.1 Introduction	16
3.2 SCC Lorry Route Network	16
4 Site Accesses and HGV Routes	18
4.1 Introduction	18
5 Site Access Reviews, Crane Route Reviews and AIL Route Review Summary	34
5.1 Introduction	34
5.2 Sunnica West Site A and East Sites A and B Accesses Review Summary	34
5.3 Summary of Grid Connection Route A and Grid Connection Route B Site Access Review	36
5.4 AIL Route Reviews Summary	37
5.5 Sunnica West Site A – La Hogue Road	41
5.6 Sunnica East Site A – Ferry Lane and Beck Road	43
5.7 Sunnica East Site B – Elms Road	53
5.8 Burwell National Grid Substation Extension	55
5.9 Summary of Site Accesses	57
5.10 Indicative Staff Car Park Layouts	59
5.11 Stage 1 Road Safety Audit	60
6 Summary of Traffic Management Proposals and Summary of Speed Surveys	62
6.1 Introduction	62
6.2 Summary of Speed Surveys	63

6.3	Temporary Road and PRow Closures	64
6.4	Summary of Temporary Traffic Signals and Temporary Speed Limits	67
7	Management	68
7.1	Introduction	68
7.2	Management Measures and Controls	68
7.3	Management Structure	76
7.4	Monitoring and Review	78
8	Compliance and Enforcement	80
8.1	Introduction	80
8.2	Compliance	80
	Annex A – Figures	82
	Annex B – SCC Lorry Route Map and CCC Advisory Freight Map	83
	Annex C – Site Access Drawings	84
	Annex D – Crane and AIL Routes Review Drawings	85
	Annex E – Stage 1 Road Safety Audit	86
	Annex F – Speed Surveys	87
	Annex G – 46.63m AIL Report	88

Table of Figures

Figure 1: Site Location	2
Figure 2: Sunnica West Site Access Locations	22
Figure 3: Sunnica East Site Access Locations	23
Figure 4: Sunnica West HGV Inbound Routes.....	24
Figure 5: Sunnica West HGV Outbound Routes.....	25
Figure 6: Sunnica East HGV Inbound Routes	26
Figure 7: Sunnica East HGV Outbound Routes.....	27
Figure 8: Burwell Substation and Cable Route HGV Inbound Routes	28
Figure 9: Burwell Substation and Cable Route HGV Outbound Routes.....	29
Figure 10: Grid Connection Route A and Grid Connection Route B Site Access Locations (Plan 1 of 4)	30
Figure 11: Grid Connection Route A and Grid Connection Route B Site Access Locations (Plan 2 of 4)	31
Figure 12: Grid Connection Route A and Grid Connection Route B Site Access Locations (Plan 3 of 4).....	32
Figure 13: Grid Connection Route A and Grid Connection Route B Site Access Locations (Plan 4 of 4)	33
Figure 14 1000T Crane (22.6m)	39
Figure 15: Swept Path Analysis – Vehicle Profile – 1000T Crane (22.6m)	39
Figure 16: 650T Crane (20.6m).....	39
Figure 17: Swept Path Analysis – Vehicle Profile – Crane (20.6m).....	39
Figure 18: 400T Crane (18.5m).....	39
Figure 19: Swept Path Analysis – Vehicle Profile – 400T Crane (18.5m)	39
Figure 20: Swept Path Analysis – Vehicle Profile – AIL (46.63m).....	39
Figure 21: Overview for Crane and AIL Route Reviews	40
Figure 22: Swept Path Analysis – 1000T Crane and 46.63m AIL – A11 / La Hogue Road Junction.....	42
Figure 23: Swept Path Analysis – 1000T Crane and 46.63m AIL – A11 / B1085 Junction.....	46
Figure 24: Swept Path Analysis – 1000T Crane and 46.63m AIL – B1085 ‘S’ Bends adjacent to La Hogue Road Junction.....	47
Figure 25: Swept Path Analysis – 1000T Crane and 46.63m AIL – B1085 ‘S’ Bends Chippenham (1 of 2)	48
Figure 26: Swept Path Analysis – 1000T Crane and 46.63m AIL – B1085 ‘S’ Bends Chippenham (2 of 2)	49
Figure 27: Swept Path Analysis – 1000T Crane and 46.63m AIL – B1102 The Street / Mildenhall Road Junction	50
Figure 28: Swept Path Analysis – 1000T Crane and 46.63m AIL – B1102 Mildenhall Road / Ferry Lane Junction.....	51
Figure 29: Swept Path Analysis – 1000T Crane and 46.63m AIL – Beck Road / Ferry Lane Junction	52
Figure 30: Swept Path Analysis – 1000T Crane and 46.63m AIL – A11 Northbound Off-Slip/Elms Road Junction	54
Figure 31: Swept Path Analysis – HGV – Weirs Drove / Newnham Drove Junction ..	56
Figure 32: Indicative Car Park Layout – Sunnica West (La Hogue Road).....	59
Figure 33: Indicative Car Park Layout – Sunnica East (Elms Road).....	59

Table of Plates

Plate 1: Forecast Total HGVs Deliveries (Single Direction) per Day

Plate 2: Forecast Total Staff Vehicles Per Day (Single Direction)

Table of Tables

Table 2-1: Summary of Forecast Daily HGVs (Vehicles, Single Direction) per Construction Month.....	9
Table 2-2: Summary of Cranes and AILs across the 24-Month Construction Period (Vehicles).....	11
Table 3-1: SCC Lorry Route Types.....	16
Table 3-2: CCC Lorry Route Types.....	17
Table 6-1: Summary of Speed Surveys: Average and 85 th Percentile (mph).....	64

1 Introduction

1.1 Background

1.1.1 AECOM has been appointed by the Applicant to provide transport planning advice in relation to the proposed energy farm comprising solar PV and battery storage (hereafter referred to as the 'Scheme') on land near Red Lodge, Suffolk (hereafter referred to as the 'Sunnica East Site A' and 'Sunnica East Site B') and Chippenham, Cambridgeshire (hereafter referred to as the 'Sunnica West Site A'). The main components of the Scheme are as follows:

- Sunnica East Site A (straddling the administrative area of West Suffolk Council (WSC) and Suffolk County Council (SCC) and Cambridgeshire County Council (CCC) and East Cambridgeshire District Council (ECDC) is located approximately 3.5 kilometres (km) east of Mildenhall, 0.5km south-east of Isleham and 0.6km south-west of West Row;
- Sunnica East Site B (within the administrative areas of WSC and SCC) is located approximately 1.5km south-east of Mildenhall, 1.5km east of Freckenham and immediately south of Worlington;
- Sunnica West Site A (within the administrative areas of ECDC and CCC) is located approximately 0.3km east of the village of Snailwell, 1km south of Chippenham and 1.5km west of Kennett, immediately north of the A14 at Newmarket;
- Burwell National Grid Substation Extension. The Sites will connect to the National Grid system at Burwell, at an existing substation; and
- The cable route corridor for Grid Connection Route A is located between Sunnica East Site A and Sunnica East Site B and then between Sunnica East Site B to Sunnica West Site A. Grid Connection Route B is located between Sunnica West Site A and Burwell National Grid Substation Extension.

1.1.2 The Sunnica East Site A, Sunnica East Site B and Sunnica West Site A are approximately 223 hectares (ha), 319ha and 373ha, respectively. Collectively, these are referred to as the Sites in this Environmental Statement and have a combined area of 981ha.

1.1.3 The Scheme qualifies as a Nationally Significant Infrastructure Project and will require a Development Consent Order (DCO) from national government, due to its generating capacity. It is an Environmental Impact Assessment development. Consultation has taken place in 2020 and 2021, in accordance with the requirements of the Planning Act 2008, which governs the DCO application process.

1.1.4 The location of the Scheme is shown in Figure 1 and in **Annex A**.

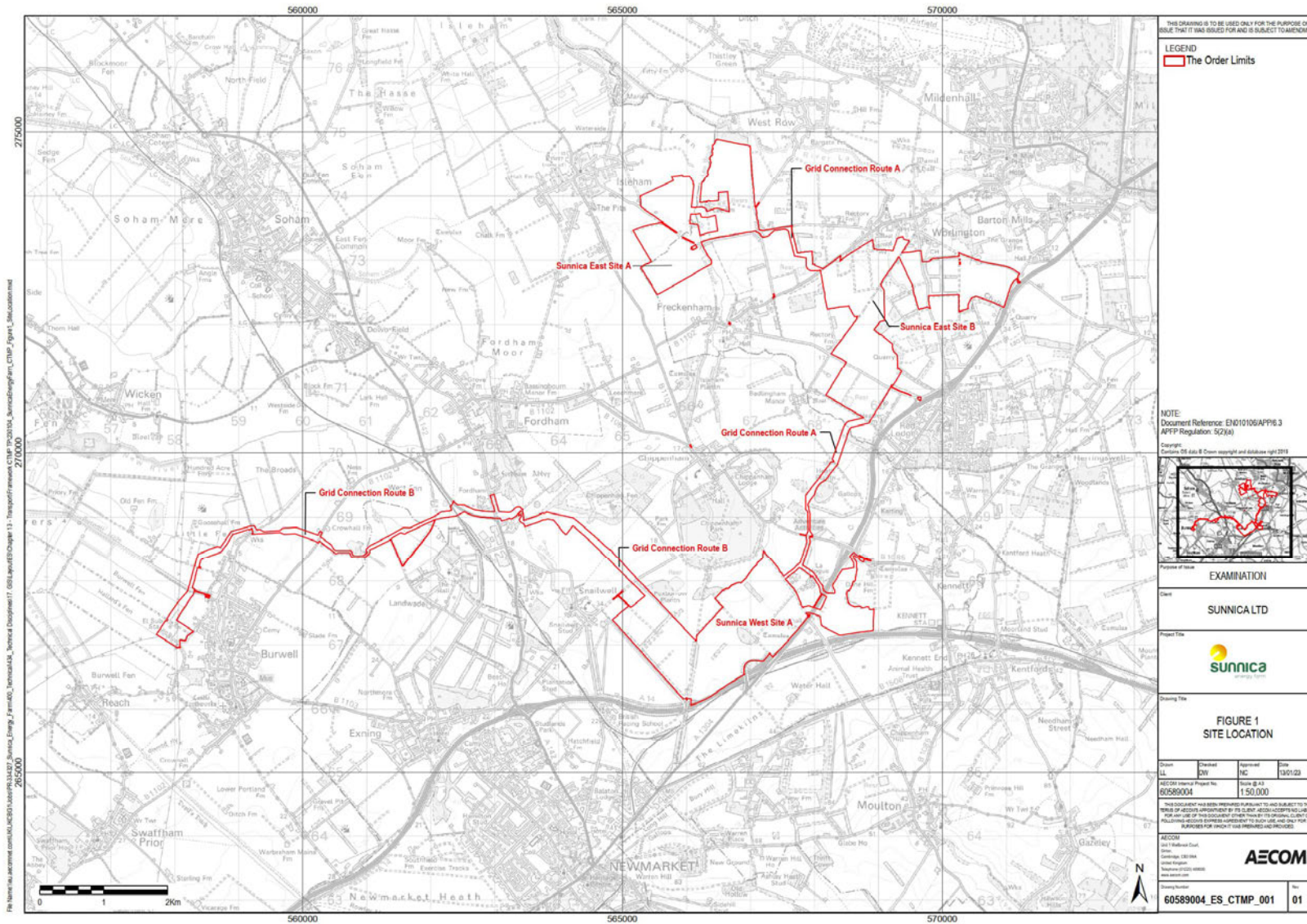

Figure 1: Site Location

1.2 Scope

- 1.2.1 This Framework CTMP & TP accompanies the application for a DCO to the Planning Inspectorate for the Scheme. This Framework CTMP and TP has been developed as the project has progressed. It is anticipated that the DCO, if granted, would include a requirement for the Framework CTMP and TP to be developed into a final CTMP and TP (either as a combined document or as separate documents) that would be submitted for the approval of the relevant county authority (or authorities), before construction is begun. The DCO, would therefore, secure that its measures are complied with. To clarify, the intention is for the final CTMP and TP to be two separate documents. However, if the contractor considers it appropriate, the two documents could remain as one single document, as functionally it is likely to make little difference in their application.
- 1.2.2 This Framework CTMP and TP sets out the Applicant's proposals to manage construction traffic and staff vehicles during the construction of Sunnica Energy Farm. It identifies the management of freight traffic (i.e. Heavy Goods Vehicles (HGVs)), as well as staff vehicles to the two centralised car parks located on La Hogue Road and Elms Road.
- 1.2.3 It should be noted that as this is a framework document, it sets out what the Applicant would undertake to manage the impact of construction traffic, however certain details remain to be developed as the Scheme progresses into detailed design. The full detail of all measures may not be available until after consent for the Scheme has been granted and so this Framework CTMP and TP sets out the measures that will be implemented in accordance with the requirements of the DCO, if granted.
- 1.2.4 Within each section of this Framework CTMP and TP a summary is included on the purpose of the section and if it is expected to be updated in the final CTMP and TP.

1.3 Scheme Updates

Change Report 1

- 1.3.1 To facilitate the grid connection at Burwell National Grid Substation, the Scheme needs to provide a substation or transformer capable of upgrading the voltage of the electricity generated by the Scheme to 400 kilovolts (kV). As part of the Applicant's Change Request [AS-243] made in August 2022, Option 1 of the National Grid Substation Extension has been removed from the scheme and so there is one remaining option in the application for a substation extension in the vicinity of the Burwell National Grid Substation. Therefore, the reference to the different extensions to the existing Burwell Substation has been removed from this document.
- 1.3.2 Through the relevant representations process, the Applicant was made aware of the representation made by National Grid Electricity Transmission (NGET). This representation stated that one of the two grid connection options, Option 1, is considered 'not technically feasible' by NGET. Option 1 will therefore not be taken forwards and reference has been removed from this document.

- 1.3.3 Following NGET's representation, the Applicant has revisited the technical solutions available to connect the Scheme into the NGET infrastructure at Burwell to seek to minimise compulsory acquisition requirements and environmental effects.
- 1.3.4 This design work has resulted in the identification of an additional option for the grid connection, referred to as 'Option 3'. Option 3 involves transforming the 33 kV received from the solar stations within the PV Sites directly to 400 kV within the onsite substation at Sunnica West Site A, Sunnica East Site A and Sunnica East Site B for export to the Burwell National Grid Substation.
- 1.3.5 At the time of Change Application **[AS-243]** Option 2 was retained in the application whilst discussions continue with NGET about Option 3. Once NGET have confirmed that they are content with Option 3, the Applicant intended to seek to remove Option 2 from the application. As a result, the Applicant has undertaken additional swept path analysis (vehicle tracking) to ensure that the electrical infrastructure required under Option 3 i.e. a 400kV transformer using a 46.63m AIL, can be safely transported to Sunnica West Site A, Sunnica East Site A and Sunnica East Site B.

Change Report 2

- 1.3.6 The Applicant has made changes to the Application, which are set out in the Applicant's Second Change Application document **[REP5-059]** submitted on 13th January 2023, and accepted by the Examining Authority. This Framework Construction Traffic Management Plan and Travel Plan (Framework CTMP & TP) has subsequently been updated to reflect those changes. A summary of the transport related features within the Change Report 2 are provided below:
- Change 1: Removal of Option 2 National Grid Substation Extension
 - Removal of 13 AILs and associated vehicle movements to/from Cable Route Site Access B on Newnham Drive (CR-B)
 - Removal of the requirement for traffic management measures associated with the safe passage of AILs. This includes the measures set out within Section 5.8 of previous iterations of the F-CTMP/TP and the road closure on Weirs Drive (RC1A-RC1B)
 - The likely removal of the requirement of the temporary road closure along Newnham Drive (RC2A-RC2B). This measure was proposed in order to safely deliver the works required to enable AIL access. The level of work required has been significantly reduced as the AIL access is no longer required. However, the temporary measure has been retained within the Application and would be implemented if the contractor or the Local Highway Authority considered it necessary to implement during the highway works at the Weirs Drive/Newnham Drive T-junction to undertake the required widening to accommodate the movement of HGVs during the construction phase.
 - Table 2.1 of previous iterations of this F-CTMP/TP sets out that the Burwell Substation Extension will require nine HGVs per day in Months 3-5, eight HGVs per day in Months 6-7, and one HGV per day in Month 8. These HGV movements have been assessed in the Transport and Access Chapter of the ES **[APP-045]**, but will no longer be required as a result of Change 1. This document has been updated to reflect this.

- Change 2: Removal of Sunnica West Site B
 - Removal of the use of the Sunnica West Site B: Site Access D (SW-D) on Fordham Road, in both the construction and operational phases. It also removes the need for HGVs to travel through Snailwell.
 - The removal of a peak of five daily HGVs travelling to/from Sunnica West Site B: Site Access D on Fordham Road, through Snailwell during the construction period.
 - Removal of the temporary traffic management on Fordham Road (TS5 and SL-3C) and Snailwell Road (SL-3B) which are associated with the use of Sunnica West Site B: Site Access D during the construction period.
 - Cable Route Site Access M on Chippenham Road will continue to be used as a construction access for the Cable Route, as is part of the current scheme proposals. It is unlikely that Cable Route Access M will be required during operation, as this will only be required if there is a fault along the cable corridor. If this is the case, access will be facilitated using Temporary Traffic Management as per the construction phase, for such a limited period as required.
 - As a result of the removal of Sunnica West Site B there will be a reduction in the level of work required to construct the scheme, i.e. the total number of construction person days required to construct the scheme will reduce. This is likely to manifest as a reduction in the average and peak numbers of staff travelling to/from the Sunnica West construction car park throughout the construction phase. Some staff who would otherwise be working on Sunnica West Site B may be redeployed to Sunnica West Site A, so it is recognised that it is unlikely to be a pro-rata reduction in staff numbers. Any such redeployment would result in a reduction in the programme duration for completing construction of Sunnica West Site A, whilst remaining within the overall peak trip envelope assessed for Sunnica West. The Applicant proposes to retain the control mechanism of a cap in vehicle numbers for the main site accesses and the Scheme as a whole, as established in 7.2.38 of this Framework CTMP & TP.
- Change 3: Inclusion of additional archaeological offset areas
 - No change in terms of transport and access.
- Change 4: Removal of 'Campus Access Road' to HPUT's premises, being one of the access options for the cable route corridor between what was West Site B and Burwell Substation. This removal follows on-going negotiations with HPUT and its tenants.
 - This involves the removal of Grid Connection Site Access L (CR-L) from the Scheme, with access to the Cable Route corridor being taken solely from Grid Connection Site Access K (CR-K).

1.4 Update to this Document

- 1.4.1 This Framework CTMP and TP has been updated as a result of the Examination questions, the Local Highway Authorities Local Impact Report, and further submissions to the Examination. Reference is made throughout the document to where an update has been made to either the Examination questions or the Local Impact Report. The update to this version of the document is Rev 05.
- 1.4.2 It is noted that during the consultation with the local highway authorities that the highway commonly referred to and referenced as 'Ferry Lane' is actually called Freckenham Road with the USRN of 14601046. The reference has been maintained as Ferry Lane throughout this document with reference added to Freckenham Road and the USRN which is available from [REDACTED]

1.5 Objectives

1.5.1 The objectives of the Framework CTMP and TP are to set a framework for the measures that would be developed in the full CTMP and TP to:

- Minimise the volume of HGV and staff vehicles associated with the construction of Sunnica Energy Farm so far as reasonably practicable;
- Maximise the safe and efficient movement of materials and staff required for Sunnica Energy Farm so far as reasonably practicable;
- Minimise the impacts both for the local community and visitors to the area using the road network so far as reasonably practicable; and
- Set out a management plan to be adhered to by those travelling to and from the site to reduce the impact of the construction of the Scheme.

1.6 Report Structure

1.6.1 This Framework CTMP and TP is structured as follows:

- **Section 2:** summarises the HGV and staff vehicle movements generated by Sunnica Energy Farm during the construction phase;
- **Section 3:** discusses SCC and CCC Freight Management Plans which set out the preferred routing options for HGVs;
- **Section 4:** details the proposed site access locations and the HGV inbound and outbound routes as well as the routes staff will be directed to use;
- **Section 5:** provides a summary of the site access reviews of Sunnica East Site A and B, Sunnica West Site A, Grid Connection Route A and Grid Connection Route B including visibility splays, swept path analysis and indicative site access layouts. This section is a summary of the crane route review which identifies the considerations given to possible routes to/from Strategic Road Network and the required site accesses including vehicle swept path analysis of 1000T, 650T and 400T cranes. This section has been updated to reflect additional swept path analysis of a 46.63m AIL, the requirement for which has been set out in the Change Report. Also summarised is the Stage 1 Road Safety Audit (RSA) for the site access located on Newmarket Road between the A11 and Golf Links Road;
- **Section 6:** provides details of the proposed traffic management including temporary traffic signals, temporary Public Right of Way (PRoW) closures, temporary speed limits and temporary traffic signals. A summary of the speed surveys undertaken is also provided in this section;
- **Section 7:** deals with management measures and control, monitoring and review of the CTMP and TP; and
- **Section 8:** deals with compliance and enforcement of the CTMP and TP.

2 Construction Movements

2.1 Introduction

2.1.1 This section summarises the HGV and staff vehicle movements that are estimated to occur during the construction of the Sunnica Energy Farm, in terms of types of vehicles, estimated number of movements (peak and average) and routeing. Further details are also provided in the Transport Assessment (TA) (**Appendix 13B** of this Environmental Statement [**APP-117**]). This section provides an overview of the forecast construction movements as background information.

2.2 Construction Period

2.2.1 Based on information provided by the Applicant, the construction of the Scheme is expected to occur over a two-year period with all sites being constructed concurrently. This is considered to be a reasonable worst-case assumption for this assessment; i.e. a longer construction period would reduce the level of daily movements.

2.3 Construction Movements

2.3.1 A summary of the freight (i.e. HGVs) movements and the routes to be taken for Sunnica East Site A and B (including two substations), Sunnica West Site A (including one substation), and the Grid Connection Route A and Grid Connection Route B is provided in the following paragraphs. A HGV refers to all vehicles exceeding 7.5 tonnes in weight. In addition, a summary of the forecast AILs and cranes are provided below in this section. The forecast flows are indicative and represent a robust assessment. They are presented to provide context to the rationale for the measures included within this document. The Full CTMP to be produced by the contractor will not need to include the construction movement analysis, but will focus on the detail of the measures to be delivered to manage the movements presented within this Framework CTMP.

2.3.2 **Table 2-1** identifies the forecast daily HGVs during each of the construction months.

2.3.3 The HGV routes have been considered following a review of the local road network and the CCC and SCC freight management plans in Section 4 of this document.

Table 2-1: Summary of Forecast Daily HGVs (Vehicles, Single Direction) per Construction Month

	Months																							
	1	2	3	4	5	6	7	8	9	10	11	12	13	14	15	16	17	18	19	20	21	22	23	24
Sunnica East Total (Sunnica East Site A & B)	35	57	53	53	42	31	27	19	18	18	18	20	31	41	31	39	36	33	25	14	21	23	12	4
Sunnica West Total (Sunnica West Site A)	25	45	48	34	30	47	47	34	29	23	19	18	17	16	15	12	11	11	10	4	14	14	0	0
HGV Total (Sunnica East Site A & B, Sunnica West Site A)	60	102	101	87	72	78	74	53	47	41	37	38	48	57	46	51	47	44	35	18	35	37	12	4
Grid Connection Total (Route A and Grid Connection Route B)	-	44	45	46	45	44	44	-	-	-	-	-	-	-	-	-	-	-	-	-	-	-	-	-
Total (Sunnica East Site A & B, Sunnica West Site A, Grid Connection Route A and Grid Connection Route B)	60	146	146	133	117	122	118	53	47	41	37	38	48	57	46	51	47	44	35	18	35	37	12	4
Average	112								37															

Sunnica West Site A

- 2.3.4 As a result of the change to remove Sunnica West Site B there is a small reduction in the number of HGVs required for Sunnica West per month. The peak HGV deliveries are forecast to occur in month three with 48 HGV deliveries per day (96 movements).
- 2.3.5 Based on a 10-hour daily construction delivery window, excluding the two highway peak hours, with movements split equally across the hours (noting that there will be more arrivals at the start of the day and departures towards the end), it would be anticipated on average of circa five HGV movements per hour to the Sunnica West Site and circa ten HGV movements per hour during peak period of activity.

Sunnica East Site A and B

- 2.3.6 It is anticipated that on average there will be 26 HGV deliveries (52 vehicle movements) per day to the Sunnica East Site during the construction phase. The peak HGV deliveries are forecast to occur in month three and four with 43 HGV deliveries per day (86 movements). This is outlined in Section 5.4 in the Transport Assessment (**Appendix 13B** of this Environmental Statement [**APP-117**]).
- 2.3.7 Assuming a 10-hour typical construction delivery window, excluding the two highway peak hours, with movements split equally across the hours (noting that there will be more arrivals at the start of the day and departures towards the end), there would be anticipated on average to be circa four HGV movements in an hour to the Sunnica East Site and five HGV movements in an hour during the peak month of activity.

Grid Connection Route A and Grid Connection Route B

- 2.3.8 It is anticipated that Grid Connection Route A and Grid Connection Route B will be constructed in a seven-month period towards the start of the construction period.
- 2.3.9 The construction of Grid Connection Route A and Grid Connection Route B is forecast to take place across a six-month window, with the seventh month when a small number of construction staff will remain on-site. Grid Connection Route A and Grid Connection Route B are expected to be constructed evenly over the six-month window. Therefore, on average there will be 23 HGV deliveries (46 vehicle movements) per day to each section of Grid Connection Route A and Grid Connection Route B. This is outlined in Section 5.4 in the Transport Assessment (**Appendix 13B** of this Environmental Statement [**APP-117**]).

Other Vehicles

- 2.3.10 The AILs and cranes that are expected to be required across the 24-month construction period are identified in **Table 2-2**. It is noted the number of vehicles identified in the table below are included within the totals in Table 2-1.
- 2.3.11 As per the government guidance, an AIL is a vehicle which has any of the following:
- 'A weight of more than 44,000kg
 - An axle load of more than 10,000kg for a single non-driving axle and 11,500kg for a single driving axle
 - A width of more than 2.9 metres

- A rigid length of more than 18.65 meters’.

Table 2-2: Summary of Cranes and AILs across the 24-Month Construction Period (Vehicles)

Vehicle	Sunnica West A	Sunnica East A	Sunnica East B	Total
80 tonne crane	4	4	4	12
400 tonne crane	2	2	2	6
1000 tonne crane	1	1	1	3
STGO CAT 2 Low Loader (AIL)	4	4	4	12
STGO CAT 3 Low Loader (AIL)	2	2	2	6
Total	13	13	13	39

2.3.12 These AILs and cranes are expected at the Sunnica West Site A main access on La Hogue Road, Sunnica East Site A on Beck Road, and Sunnica East Site B main access on Elms Road. There will be no requirement for AILs to access the Burwell National Grid Substation on Newnham Drive. Further information regarding the AIL and crane routes is provided within Section 5.

Total HGV Construction Vehicles

- 2.3.13 For Sunnica West Site, Sunnica East Sites, substations and Grid Connection Route A and Grid Connection Route B, it is forecast there would be a peak of 155 HGV deliveries per day across the Order limits.
- 2.3.14 During the eight-month period which includes the substations and Grid Connection Route A and Grid Connection Route B, an average of 119 HGV deliveries per day are anticipated across the Order limits. Once the substations and Grid Connection Route A and Grid Connection Route B have been constructed, an average of 38 HGVs deliveries per day are forecast across the Order limits for the remaining 16-months construction period.
- 2.3.15 **Plate 1** identifies the forecast total number of HGV deliveries (vehicles single direction) per day across the construction period.

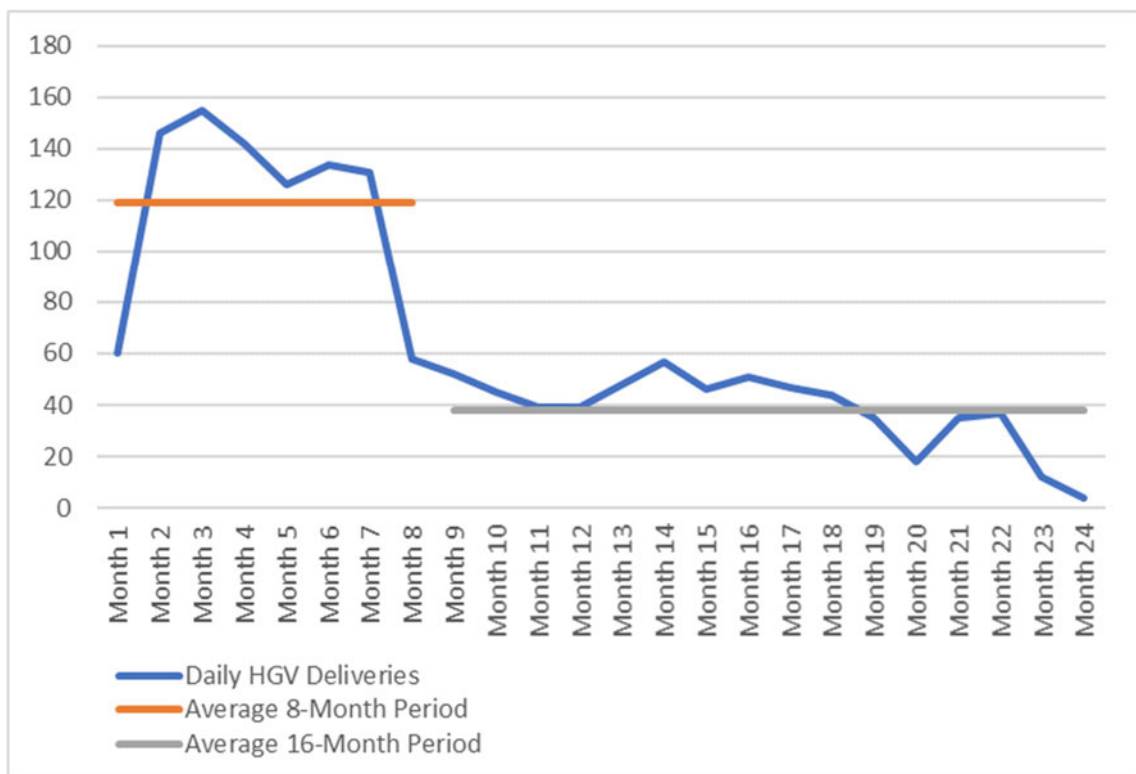

Plate 1: Forecast Total HGVs Deliveries (Single Direction) per Day

2.4 Staff Movements

- 2.4.1 The construction of the three substations and the Grid Connection Route A and Grid Connection Route B are forecast to occur within an eight-month period towards the start of the construction period. Staff relating to all substations will be required to enter the central car parks at the main access to Sunnica West Site A (La Hogue Road) or Sunnica East Site B (Elms Road).
- 2.4.2 For the Sunnica West Site A substation, staff will be required to travel to the Sunnica West Site A car park. Whereas, for Sunnica East Site A and Site B substations, staff will be required to travel to the Sunnica East Site B central car park.
- 2.4.3 As the Grid Connection Route A and Grid Connection Route B are being constructed in two sections, staff will be able to travel to/from the required accesses as the construction progresses. In total the Grid Connection Route A and Grid Connection Route B are forecast to generate an average of six staff per day with a maximum of eight staff (a total across both Grid Connection Route A and Grid Connection Route B). This results in an average of five staff vehicles and a maximum of six staff vehicles per day over a seven-month period (across both Grid Connection Route A and Grid Connection Route B). Given the number of Grid Connection Route A and Grid Connection Route B site accesses and the area the routes cover, it is unknown which site accesses staff will require and when. However, given the low number of forecast staff and staff vehicles, it is not considered that the addition of the Grid Connection Route A and Grid Connection Route B staff and staff vehicles would have a significant impact on the total forecast staff and staff vehicle totals.
- 2.4.4 Therefore, the Sunnica West Site A staff total and staff vehicles discussed below includes staff relating to the main construction at Sunnica West A, including the substation. The Sunnica East Sites A and B staff totals discussed below includes staff relating to the main construction at Sunnica East Site A and B and the two substations located at Sunnica East A and B, respectively.
- 2.4.5 The Traffic and Transport Chapter of the Environmental Statement [APP-117] assessed a worst case scenario of a larger scheme than is now proposed which included development at Sunnica West Site B, and a substation extension at Burwell. The peak number of staff required for the Sunnica West Sites A and B including the Burwell National Grid Substation Extension, is forecast to occur in month 12 with 777 staff per day. The peak number of staff required for the Sunnica East Sites A and B is forecast to occur in month six with 834 staff per day. The peak number of staff across the Scheme is forecast to occur in month nine of the construction period with 1,393 staff per day. Across the entire construction period the average number of staff required for the Sunnica West Sites A and B including the Burwell National Grid Substation Extension is forecast to be 439 staff and 525 staff for the Sunnica East Sites A and B resulting in an average of 966 staff per day across the Scheme.
- 2.4.6 As a result of the removal of Sunnica West Site B there will be a reduction in the level of work required to construct the scheme, i.e. the total number of construction person days required to construct the Scheme will reduce. This is likely to manifest as a reduction in the average and peak numbers of staff travelling to/from the Sunnica West construction car park throughout the construction phase. Some staff

who would otherwise be working on Sunnica West Site B may be redeployed to Sunnica West Site A, so it is recognised that it is unlikely to be a pro-rata reduction in staff numbers. Any such redeployment would result in a reduction in the programme for completing construction of Sunnica West Site A, whilst remaining within the overall peak trip envelope assessed for Sunnica West.

- 2.4.7 Due to the rural location of the Order limits, it is anticipated that the majority of staff will drive or be a vehicle passenger to / from the Order limits. For the purpose of this assessment, it is assumed that the number of staff vehicles required to access the site will see all staff travelling by car, with an average vehicle occupancy of 1.5 persons. This establishes the total number of vehicles that has been assessed in the Environmental Statement, and the cap which is applied to staff vehicles as set out in this F-CTMP. In practice, compliance with this cap can be achieved through a range of measures in addition to car sharing.
- 2.4.8 For the construction of the substations staff will be required to travel to either of the two central car parks depending on the substation location. Given the low number of staff required for the construction of Grid Connection Route A and Grid Connection Route B and given the construction location will change as it is progressed, the associated staff will travel to the required site access as the construction progresses.
- 2.4.9 The peak number of vehicles associated with the staff for the larger previously proposed scheme of Sunnica West Sites A and B including the Burwell National Grid Substation Extension is forecast to be 562 in month six. The peak number of vehicles associated with the staff for the Sunnica East Site A and B is forecast to be 522 in month 12. The peak number of vehicles across the Scheme is 937 vehicles per day associated with the Sites in month nine.
- 2.4.10 The average number of vehicles associated with the staff for the larger previously proposed scheme of Sunnica West Sites A and B (including the on-site substation and Burwell National Grid Substation Extension) is forecast to be 295 and 356 for the Sunnica East Site A and B resulting in an average of 653 staff vehicles per day for the Scheme for the construction period.
- 2.4.11 **Plate 2** identifies forecast total number of staff vehicles per day across the construction period, for the larger previously proposed scheme including Sunnica West Site B and the Burwell Substation Extension. The peak number of daily staff vehicles is forecast in month nine with 937 staff vehicles, whereas the average over the construction period is 653 vehicles. The maximum number of staff vehicles identified is an additional 284 vehicles (43%) higher than the average number of daily staff vehicles.

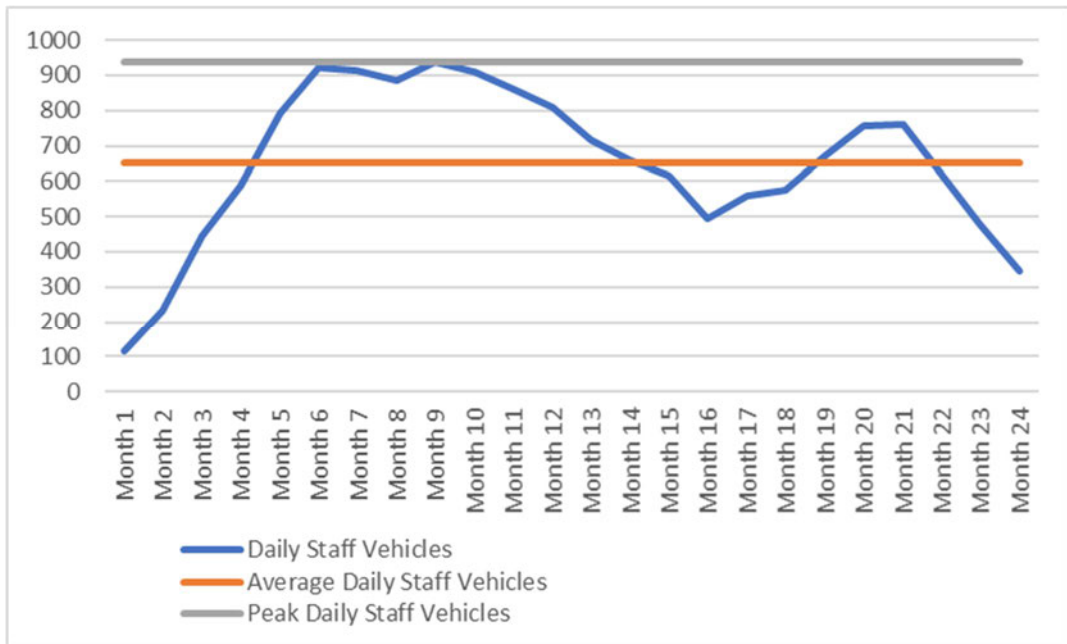

Plate 2: Forecast Total Staff Vehicles Per Day (Single Direction)

3 Local Authority Freight Management Plans

3.1 Introduction

3.1.1 SCC and CCC both operate Freight Management Plans which set out the preferred routing options for HGVs travelling within both authority areas. The Plans also identify where height and weight restrictions are in place. This section is provided as information and background as part of the process to identifying the HGV routes. This section of the Framework CTMP and TP is not expected to be updated within the final CTMP and TP unless local authority guidance is updated in the intervening period.

3.2 SCC Lorry Route Network

3.2.1 The SCC 'Lorry Route Network' illustrates the routes which SCC have identified as the recommended routes for HGVs when travelling within and through the county. There are three route types identified by SCC. The route type, the description and the roads which form those routes are set out in **Table 3-1**.

Table 3-1: SCC Lorry Route Types

Route Type	Description	Roads (Examples)
Strategic Lorry Routes	Predominantly the trunk road network and larger 'A' classified roads. All movements crossing Suffolk should use these, with those starting or ending in the county using them in preference to local lorry routes.	A11 A14 A12 A140 A143 A134
Zone Distributor Routes	Predominantly 'A' classified and 'B' classified roads. Roads within a zone serving as a route directly to a location or as a route to local access routes.	A143 A1101 A1065 B1506
Local Access Routes	Roads or part of roads serving as access to a specific location.	B1102 B1106

Source: SCC

3.2.2 In addition to the routes identified in **Table 3-1**, weight restrictions are in place on roads within Suffolk with a weight restriction of 44 tonnes on the bridge on Ferry Lane (Freckenham Road USRN: 14601046).

3.2.3 A copy of the plan illustrating which roads within Suffolk fall within which route type is included in **Annex B** of this report.

Cambridgeshire Advisory Freight Map

3.2.4 The CCC ‘Cambridgeshire Advisory Freight Map’ illustrates the routes which CCC has identified as the recommended routes for Heavy Goods Vehicles when travelling within and through the county. There are two route types identified by CCC. The route type, the description and the roads which form those routes are set out in **Table 3-2**.

Table 3-2: CCC Lorry Route Types

Route Type	Description	Roads (Examples)
Strategic Route	Predominantly the trunk road network and larger ‘A’ classified roads.	A11 A14 A142
Local Route	Predominantly ‘A’ classified and ‘B’ classified roads.	B1085 B1104 B1102

Source: CCC

- 3.2.5 In addition to the routes identified in **Table 3-2**, weight and height restrictions are in place on roads within Cambridgeshire. There are two roads within the vicinity of the Order limits which are affected by a restriction. A 3-tonne weight restriction has been placed on the bridge over the River Kennet on Badlingham Road. The bridge is located approximately 1km west of the south-western boundary of the proposed Sunnica East Site B. Badlingham Road connects with B1085 Elms Road on the sites south-western boundary. The second is located on Fordham Road/Snailwell Road (to the north of Snailwell), where a 7.5 tonne weight restriction has been placed on the bridge over the River Snail.
- 3.2.6 A copy of the plan illustrating which roads within Cambridgeshire fall within which route type is included in **Annex B** of this report.
- 3.2.7 In response to the examination question Q1.10.36, further clarification is provided regarding the purpose of Table 3-2, below.
- 3.2.8 The A11, A14 and A142 are the strategic routes that are closest to the site accesses which are identified in the Cambridgeshire Advisory Freight Map. It is noted that this does not mean the Strategic Road Network (SRN) but references key routes within Cambridgeshire. There is the potential, depending on the origin of the HGV, for the wider SRN to be used outside of Cambridgeshire. The HGV routes to and from the site accesses are provided within Figure 4 to Figure 9 of this document.

4 Site Accesses and HGV Routes

4.1 Introduction

4.1.1 This section identifies the HGV routes and the locations of the site accesses during the construction and operational phases. These figures include the following and are also provided in **Annex A** of this report:

- Figure 2 – Sunnica West – Site Access Locations;
- Figure 3 – Sunnica West – Site Access Locations;
- Figure 4 – Sunnica West – HGV Inbound Routes;
- Figure 5 – Sunnica West – HGV Outbound Routes;
- Figure 6 – Sunnica East – HGV Inbound Routes;
- Figure 7 – Sunnica East – HGV Outbound Routes;
- Figure 8 – Burwell Substation – HGV Inbound Routes;
- Figure 9 – Burwell Substation – HGV Outbound Routes;
- Figure 10 – Grid Connection Route A and Grid Connection Route B – Site Access Locations 1;
- Figure 11 – Grid Connection Route A and Grid Connection Route B – Site Access Locations 2;
- Figure 12 – Grid Connection Route A and Grid Connection Route B – Site Access Locations 3; and
- Figure 13 – Grid Connection Route A and Grid Connection Route B – Site Access Locations 4.

4.1.2 Where possible, the site accesses identified on the figures have been chosen as they are currently utilised for field access by agricultural vehicles and therefore existing access points have been reutilised rather than creating new access points.

4.1.3 The main access to the Sunnica West Site A and B is proposed to be from La Hogue Road and located in close proximity to the A11/La Hogue Road/Norwich Road junction. The reference to this junction includes the following movements outlined below and clarification has been provided due to examination question Q1.10.38.

- A11 to La Hogue Road via the northbound off-slip;
- La Hogue Road to A11 via the northbound on-slip;
- A11 to Norwich Road via the southbound off-slip; and
- Norwich Road to A11 via the southbound on-slip.

4.1.4 To minimise the number of HGVs on the local network internal routes will be used where possible from the main access point. Where HGVs are unable to use internal routes, there are various secondary access points identified which include Dane Hill Road for the site to the south of the A11 and Chippenham Road to access the Cable Route. The Sunnica West Site A substation will be accessed via La Hogue Road.

- 4.1.5 The main access to the Sunnica East Site A and B is proposed to be from Elms Road and located in close proximity to the A11 northbound off-slip/Elms Road T-junction. To minimise the number of HGVs on the local network internal routes will be used where possible from the main access point. Where HGVs are unable to use internal routes, there are various secondary access points which include Newmarket Road, Beck Road and Ferry Lane (Freckenham Road USRN: 14601046). The Sunnica East Site A substation will be accessed via the site access on Ferry Lane (Freckenham Road USRN: 14601046) with the Sunnica East Site B substation accessed via the site access on Elms Road.
- 4.1.6 The Burwell substation is an existing substation located to the northwest of the main village on Newnham Drove accessed via Weirs Drove. As a result of the proposed changes to the Scheme, a substation extension is no longer proposed at Burwell. However, works will still be required to construct Grid Connection Route B to facilitate connection of the Scheme to the national electricity grid at Burwell. Therefore, access at Cable Route Access B would be retained for those works and for maintenance during operations. The HGVs associated with the construction of Grid Connection Route A and Grid Connection Route B will use the most appropriate route available using either the routes identified to/from Sunnica West, Sunnica East or the Burwell Substation. The route selected will be set out in the CTMP and TP submitted for approval in accordance with the requirements of the DCO.
- 4.1.7 Any changes to the HGV routes included in the CTMP and TP submitted for approval in accordance with the requirements of the DCO must demonstrate that they would not lead to any materially new or materially different significant effects than those assessed in the Environmental Statement. This does not apply to the site accesses as these locations are fixed by the provisions of the DCO, as outlined in the Access and Rights of Way Plans **[REP2-006]** in accordance with article 12 of the DCO which does permit accesses at other locations but only with the approval of the relevant planning authority following consultation with the relevant highway authority.
- 4.1.8 A summary of the site accesses are provided below as a response to examination question Q1.10.24 to provide clarification on the site accesses taken forward. The site accesses are also shown on **Figure 2** to **Figure 13**.
- 4.1.9 The site accesses which are identified to be used within the operational phase are existing field accesses and are expected to be used infrequently for maintenance:
- Sunnica West Site A: Site Access A on La Hogue Road – to be used within construction, operational and decommissioning phases. The main access to the construction staff car park and the operational staff car park.
 - Sunnica West Site A: Site Access B on Chippenham Road – to be used within construction, operational and decommissioning phases. This is an existing access which is expected to be used infrequently during the operational phase for maintenance purposes.
 - Sunnica West Site A: Site Access C on Dane Hill Road – to be used within construction, operational and decommissioning phases. This is an existing access which is expected to be used infrequently during the operational phase for maintenance purposes.

- Sunnica East Site B: Site Access A on Elms Road – to be used within construction and decommissioning phases. Only to be used as emergency access during the operational phase.
- Sunnica East Site B: Site Access B on Elms Road – to be used within construction, operational and decommissioning phases. This is an existing access which is expected to be used infrequently during the operational phase for maintenance purposes.
- Sunnica East Site B: Site Access C on Elms Road – to be used within construction, operational and decommissioning phases. The main access to the construction staff car park and the operational staff car park.
- Sunnica East Site B: Site Access D and H on Newmarket Road (located between Worlington and the Red Lodge Dumbbell Roundabouts) – Site Access D to be used within the construction, operational and decommissioning phases. Site Access H to be used within the construction and decommissioning. Site Access D is an existing access which is expected to be used infrequently during the operational phase for maintenance purposes. Site Access H is not proposed to be retained during the operational phase.
- Sunnica East Site A: Site Access E on Ferry Lane (Freckenham Road USRN: 14601046) – to be used within construction, operational and decommissioning phases. This is an existing access which is expected to be used infrequently during the operational phase for maintenance purposes and for access to the substation.
- Sunnica East Site A: Site Access F on Beck Road – to be used within construction, operational and decommissioning phases. This is an existing access which is expected to be used infrequently during the operational phase for maintenance purposes.
- Sunnica East Site A: Site Access G on Beck Road – to be used within construction, operational and decommissioning phases. This site access is expected to be used infrequently.
- Sunnica East Site B: Site Access I on Newmarket Road (between A11 and Golf Links Road) – to be used within the construction phase. This site access is not intended to be retained during the operational phase.
- Sunnica East Site B: Site Access J on Golf Links Road – this is an existing access to the field and will be used for infrequent maintenance access during the operational phase only. The access to the field will not be used during the construction or decommissioning phases.
- Sunnica East Site A: Site Access K on Beck Road – to be used within construction, operational and decommissioning phases. During the construction and decommissioning phases this site access will be used for ALLs only and not HGVs. This is an existing access which is expected to be used for emergency use only during the operational phase.
- Grid Connection Site Access A: an existing site access to be used during the construction, operation and decommissioning phases related to works to connect and maintain the connection, of the project to the existing National Grid Burwell Substation.

- Grid Connection Site Access B: new construction site access to support the works to connect and maintain the connection, of the project to the existing National Grid Burwell Substation.
- Grid Connection Site Access C: an existing site access to be used during the construction of the grid connection. A smaller vehicle (10m rigid) than a 16.5m articulated HGV has been identified to use this access.
- Grid Connection Site Access D to T: existing site accesses to be used during the construction of the grid connection. As a result of proposed changes to the Scheme, Grid Connection Site Access L is no longer required for use.

- 4.1.10 The Design Principles preserve the ability to use the grid connection site accesses during operation in case it is required for infrequent maintenance purposes.
- 4.1.11 The access locations across Grid Connection Routes A and B will be re-instated to the condition they were in prior to the construction phase; however, the rights to utilise these access points will be retained during operation and secured through the DCO to allow access for maintenance, if required. Access to the Grid Connection Routes A and B is not required during decommissioning as the cable and infrastructure will remain in-situ.
- 4.1.12 In response to the Local Impact Report, further clarification is provided on the HGV routes to Sunnica East Site A: Site Access E and Sunnica East Site A: Site Access F. The HGV vehicles routes are proposed to use Freckenham Road to/from the A11 with the inbound and outbound routes shown in **Figure 6** and **Figure 7** respectively.

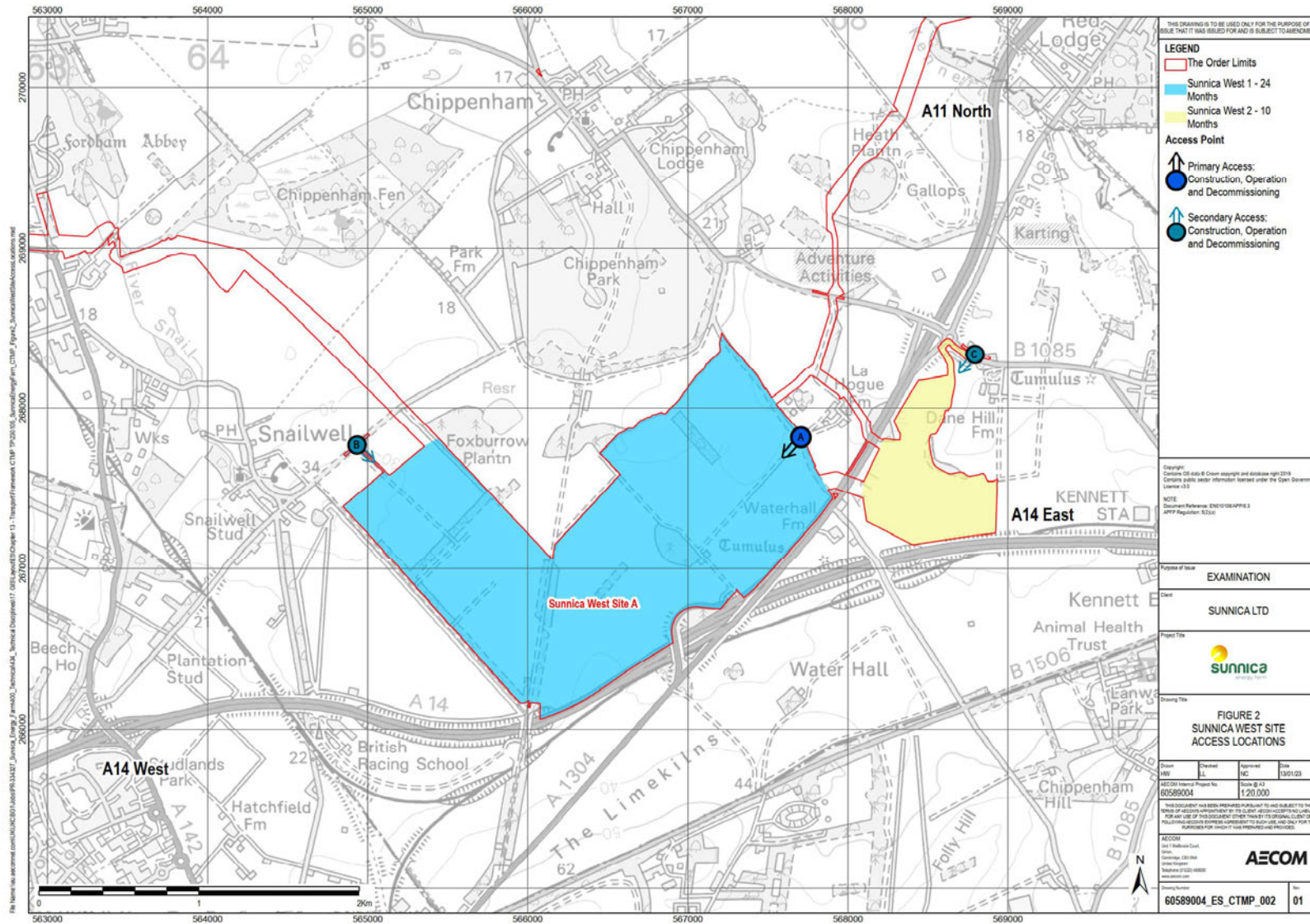

Figure 2: Sunnica West Site Access Locations

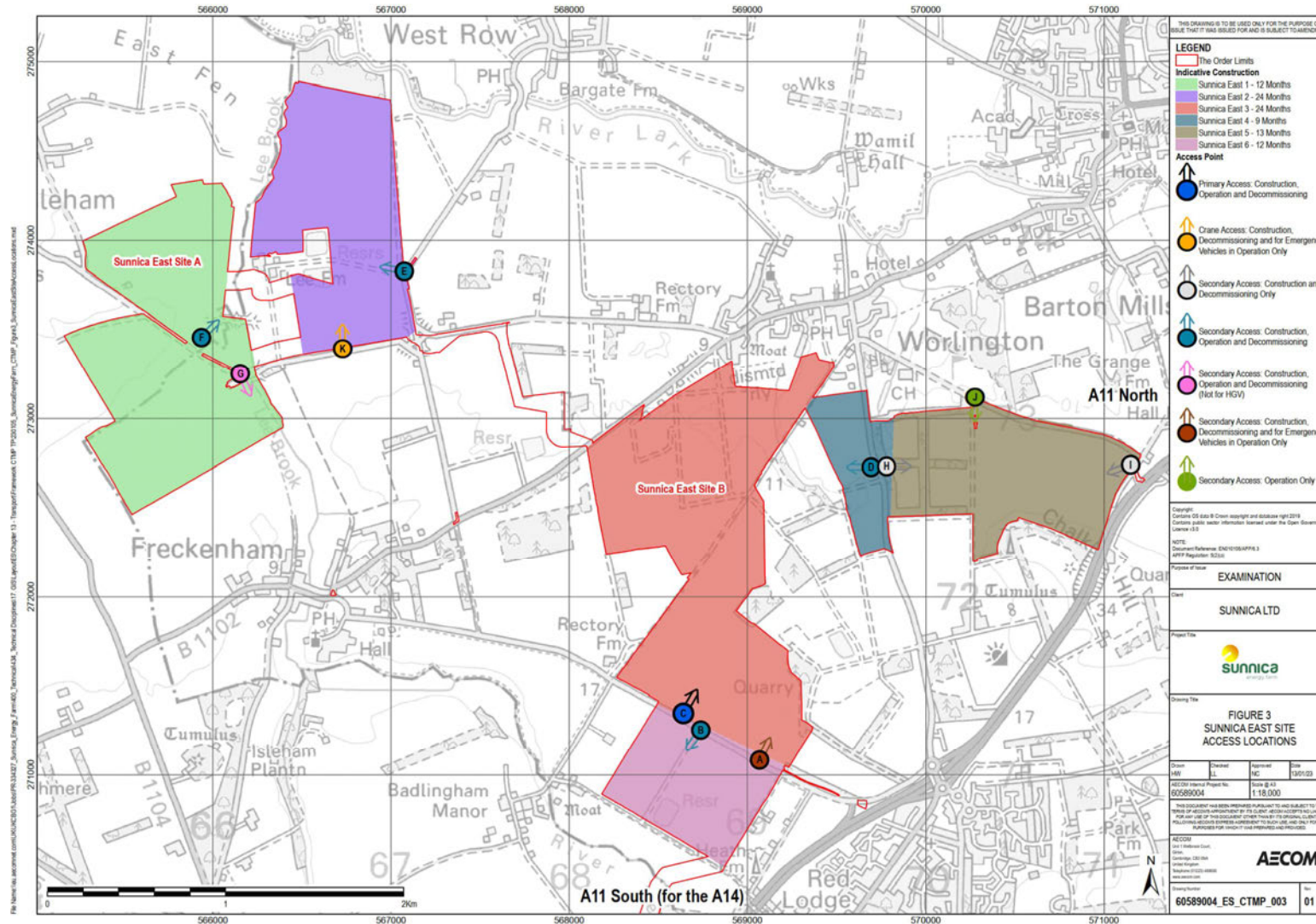

Figure 3: Sunnica East Site Access Locations

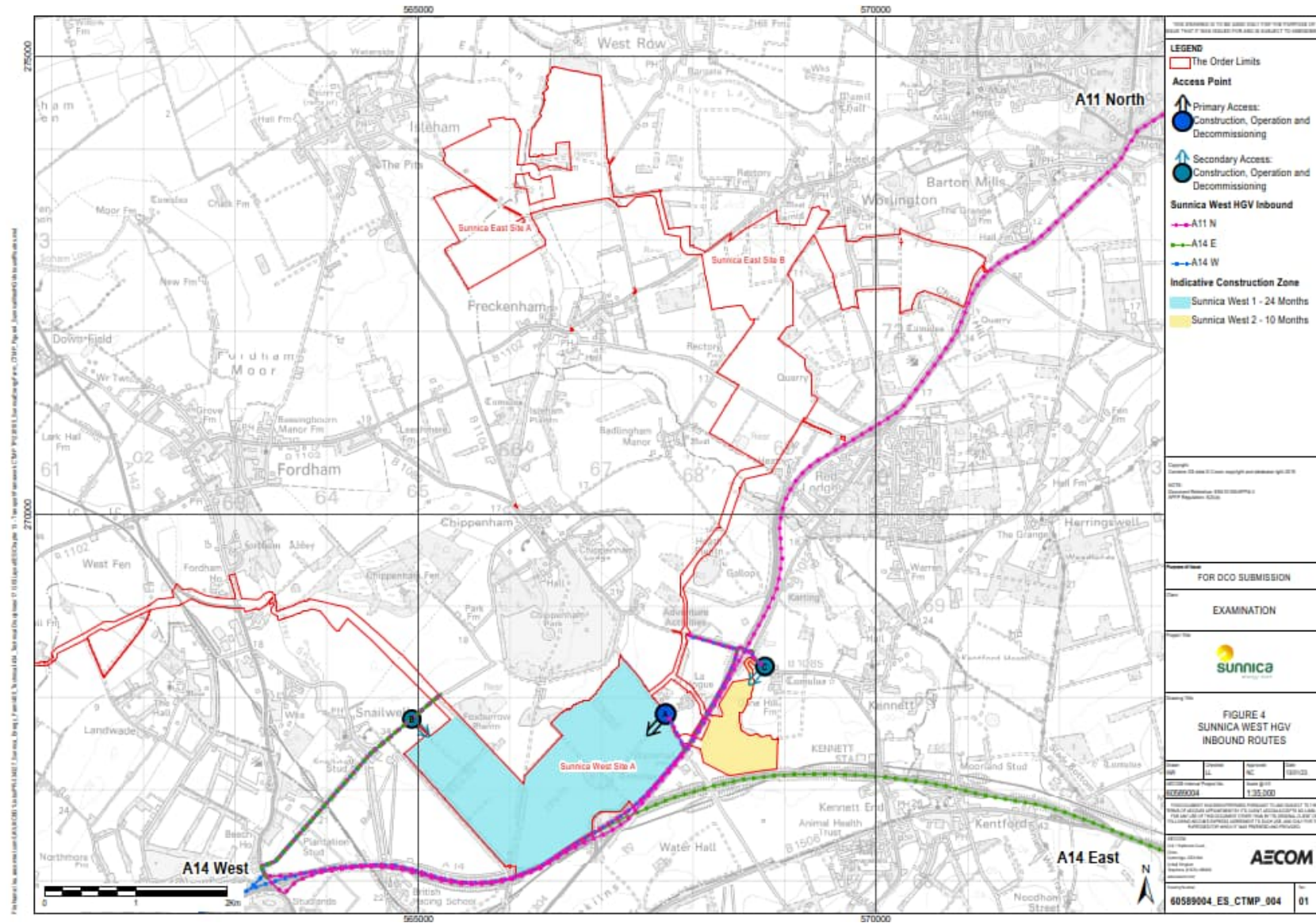

Figure 4: Sunnica West HGV Inbound Routes

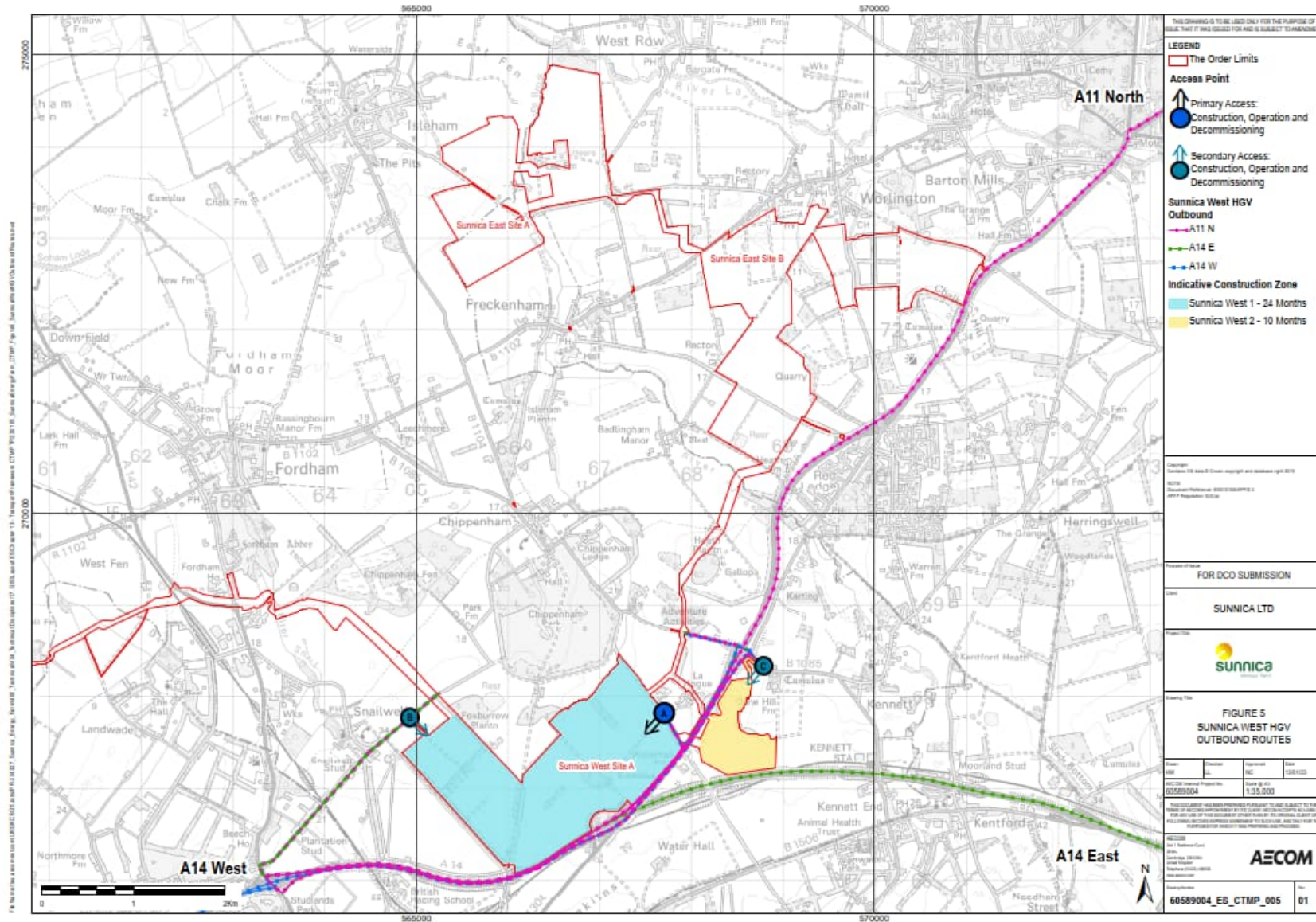

Figure 5: Sunnica West HGV Outbound Routes

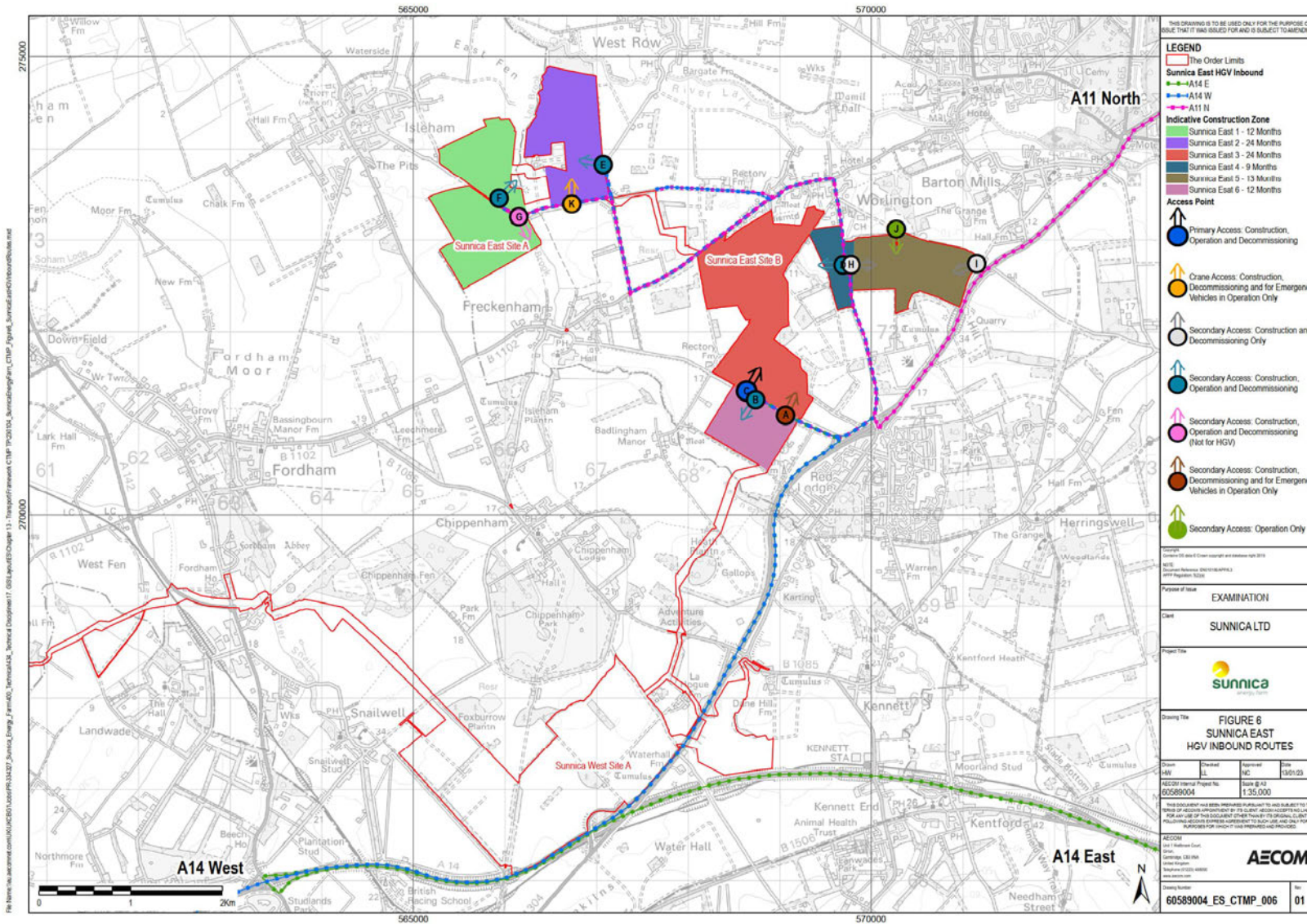

Figure 6: Sunnica East HGV Inbound Routes

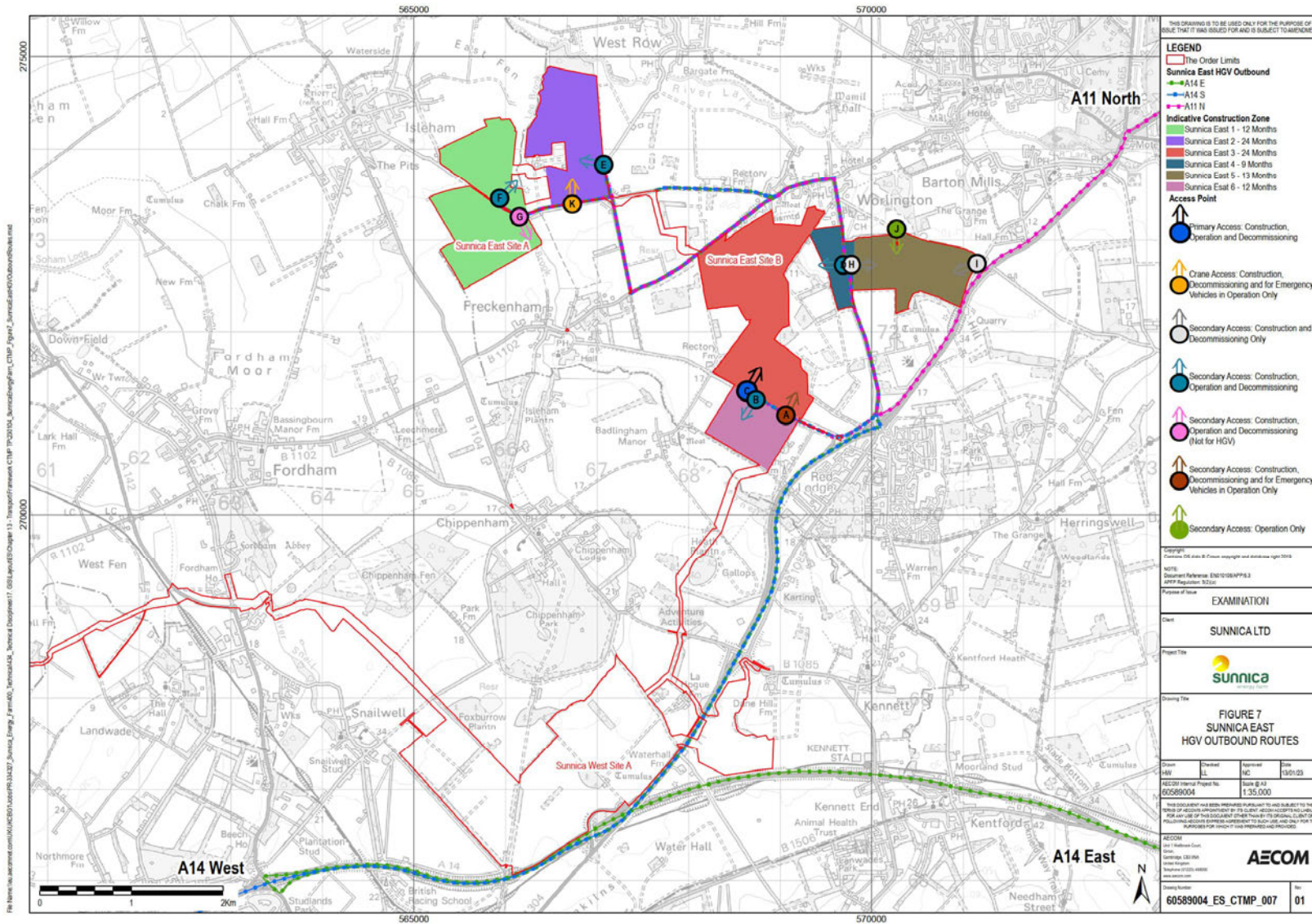

Figure 7: Sunnica East HGV Outbound Routes

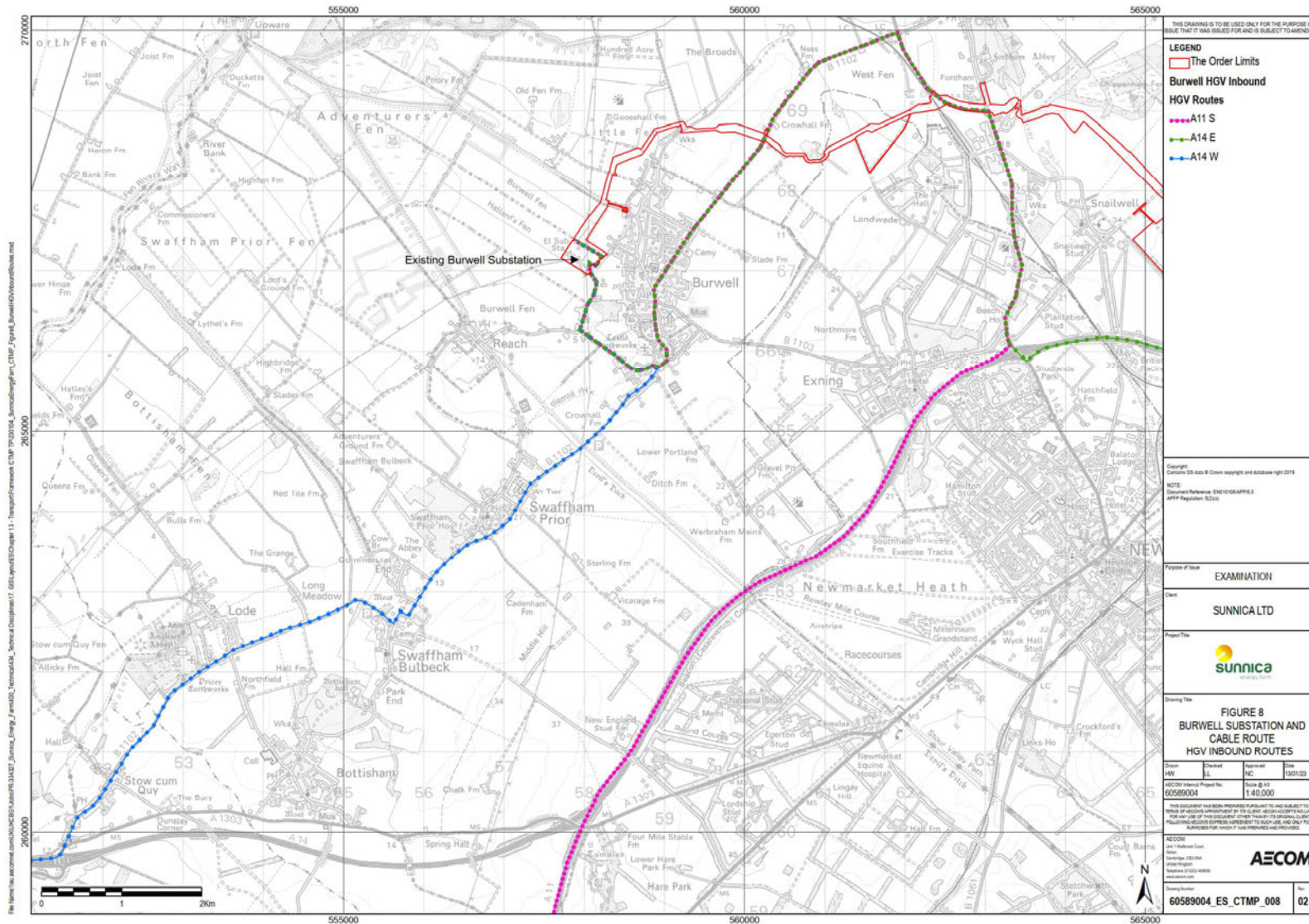

Figure 8: Burwell Substation and Cable Route HGV Inbound Routes

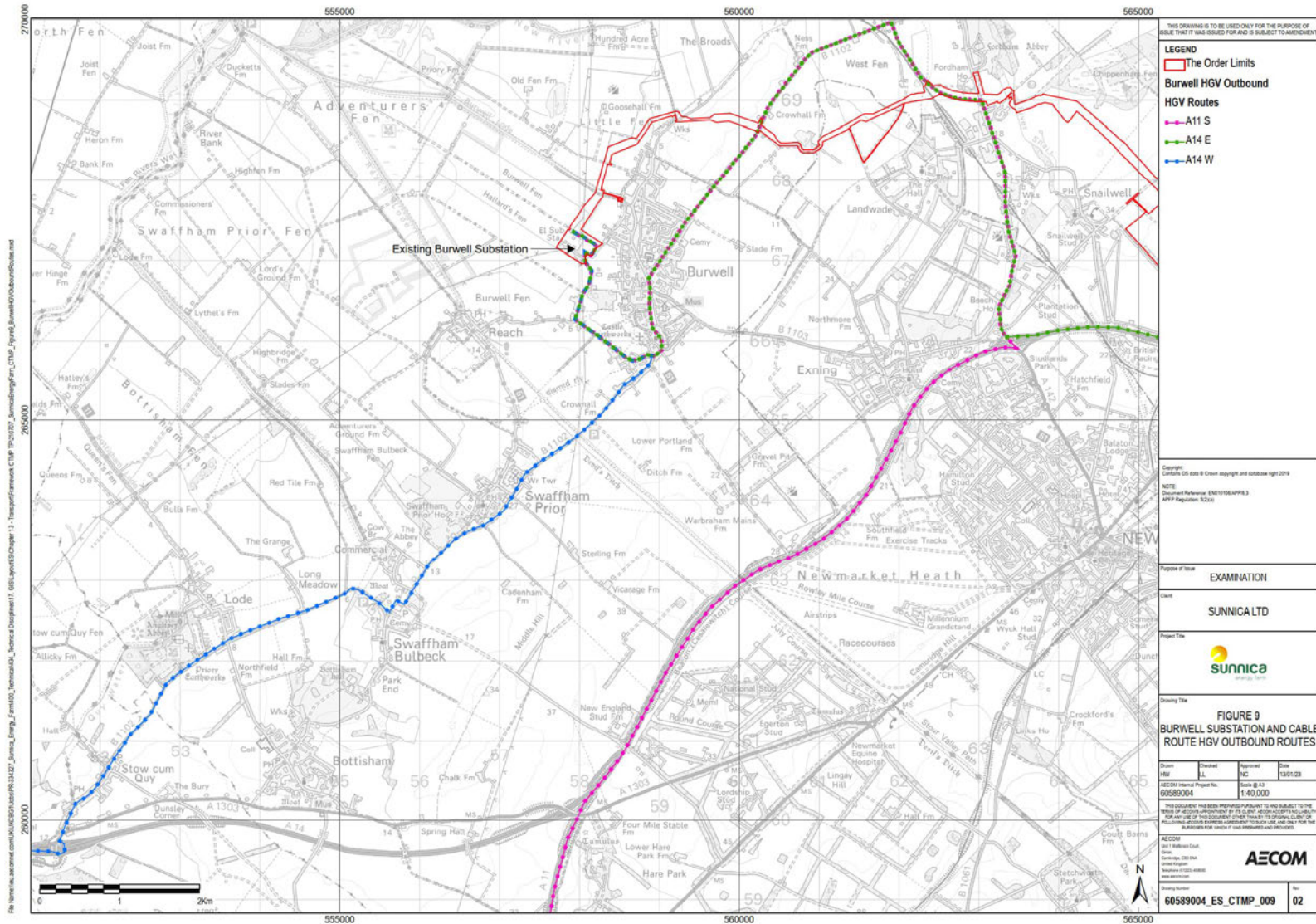

Figure 9: Burwell Substation and Cable Route HGV Outbound Routes

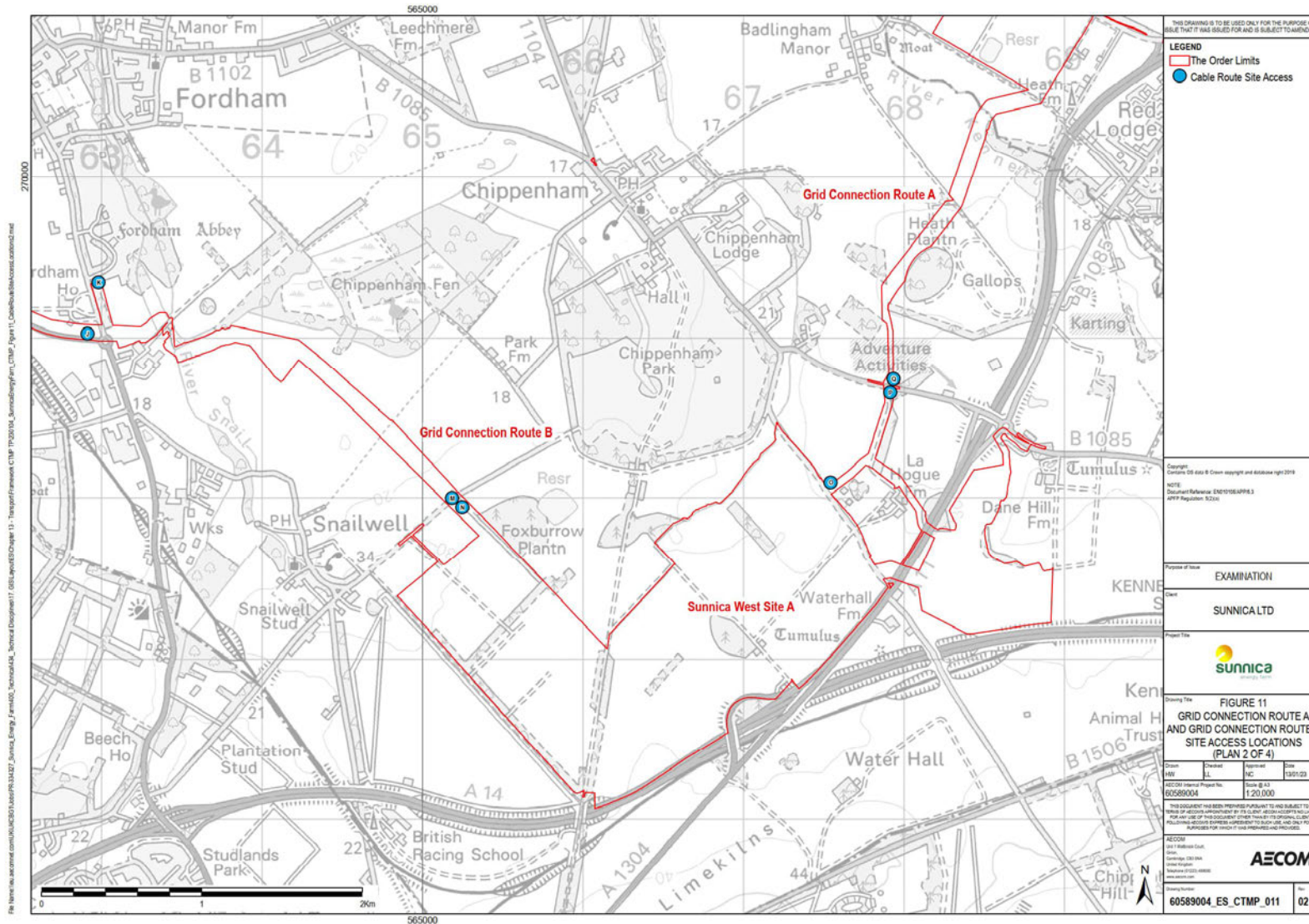

Figure 11: Grid Connection Route A and Grid Connection Route B Site Access Locations (Plan 2 of 4)

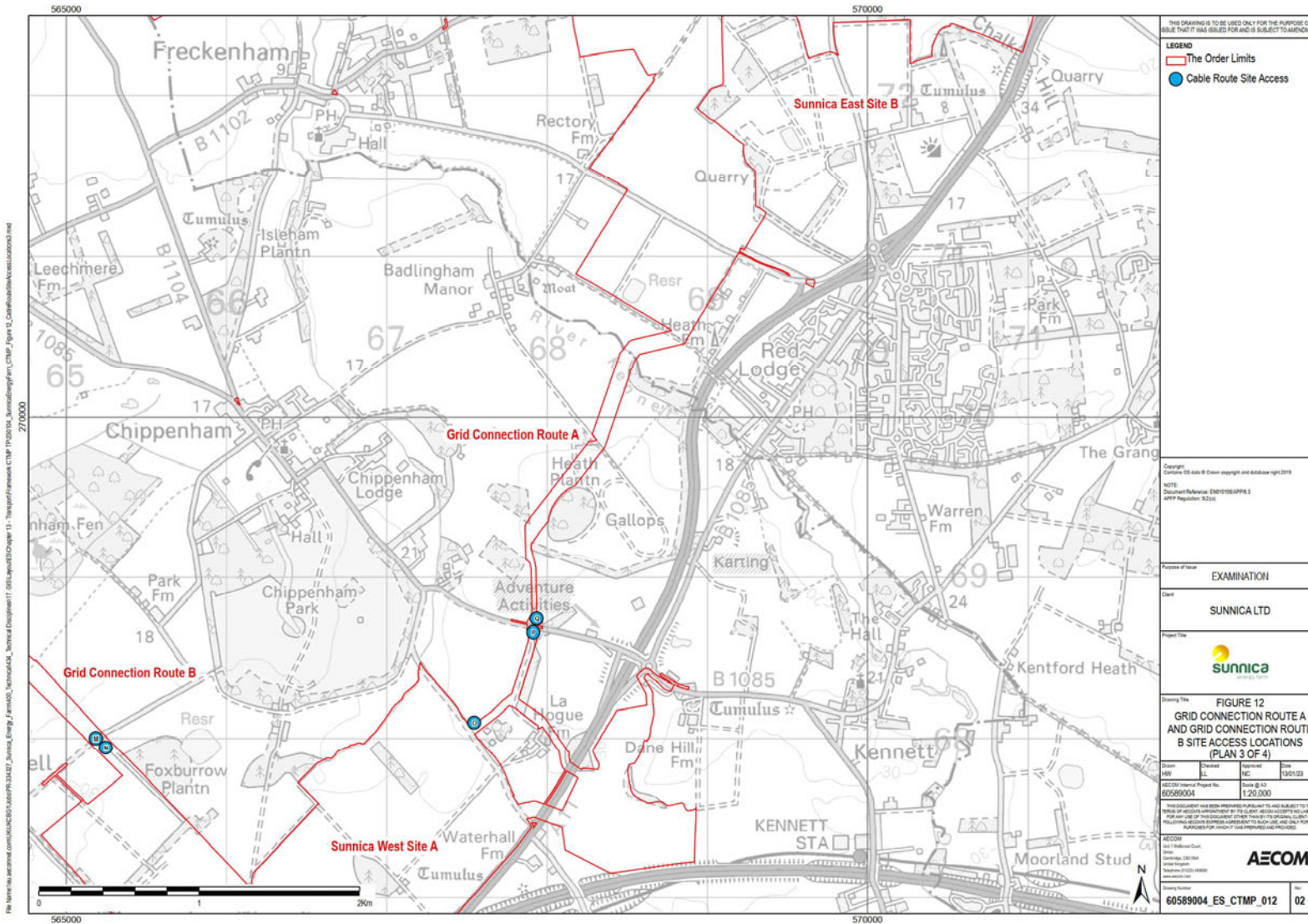

Figure 12: Grid Connection Route A and Grid Connection Route B Site Access Locations (Plan 3 of 4)

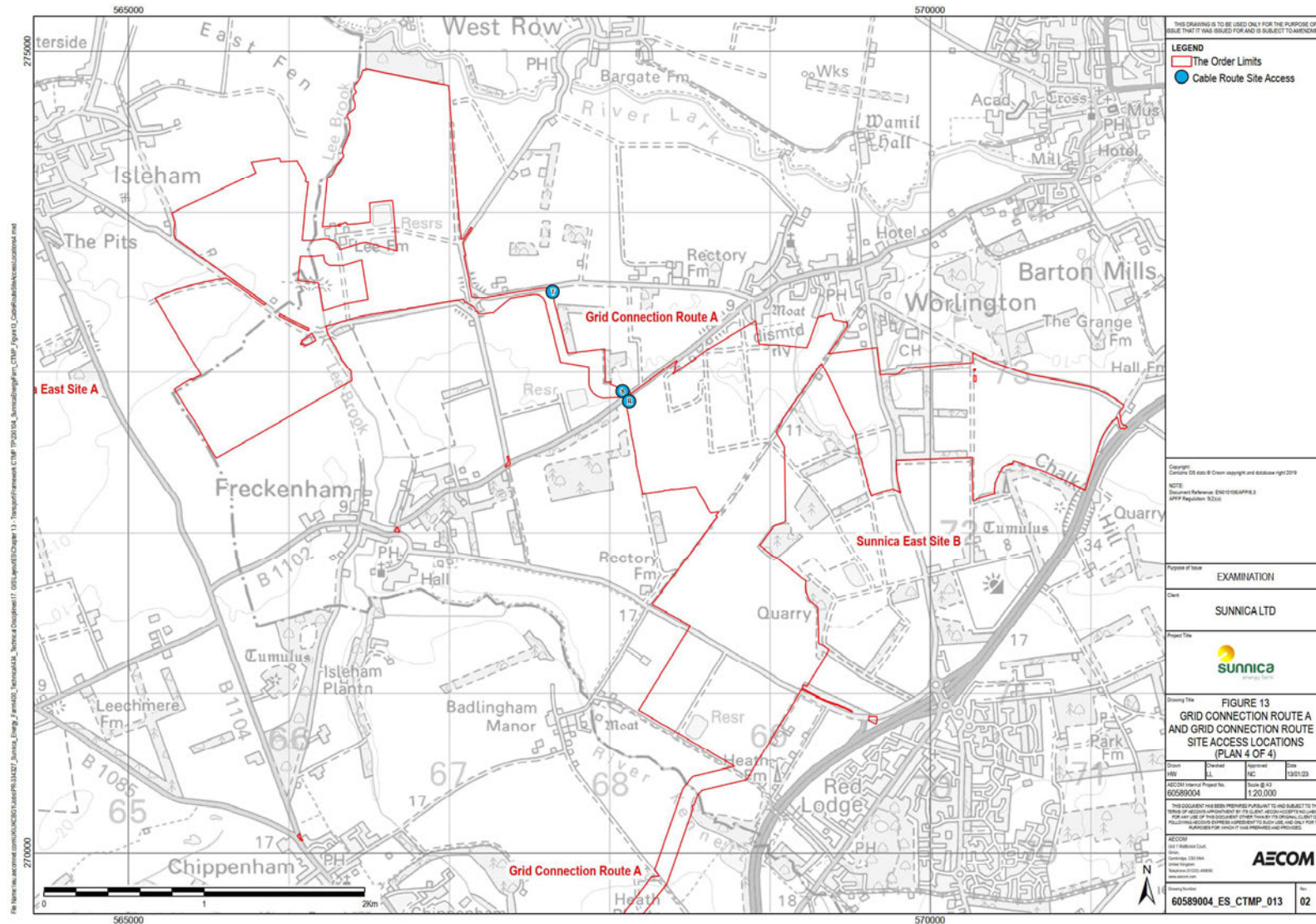

Figure 13: Grid Connection Route A and Grid Connection Route B Site Access Locations (Plan 4 of 4)

5 Site Access Reviews, Crane Route Reviews and AIL Route Review Summary

5.1 Introduction

- 5.1.1 From the consultation during the pre-examination period and after the submission, comments were received from SCC and CCC regarding further details of the site access arrangements including visibility splays, swept path analysis and junction layouts to show they can be used safely by the proposed construction vehicles.
- 5.1.2 This section of the Framework CTMP and TP provides a summary of the Sunnica East Sites A and B and Sunnica West Site A Access Review, the Grid Connection Route A and Grid Connection Route B Site Access Review and the AIL Route Reviews. Included in the site access reviews and the AIL route reviews are visibility splays, swept path analysis and junction work areas (indicative site access layouts). The Figures produced within the body of this document are included to support the reader in their understanding of the report. They are reproduced at scale in the relevant Annexes within this document, which should be referred to aid any review of the drawings' content.
- 5.1.3 This section of the Framework CTMP and TP has been updated to reflect the additional information provided to facilitate transporting a 400KV transformer to Sunnica West Site A, Sunnica East Site A and Sunnica East Site B. Further details of the 46.63m AIL are provided in section 5.4.
- 5.1.4 This section also provides details of the layout of the two centralised car parks and the summary of the Stage 1 RSA carried out for the Site access located on Newmarket Road between the A11 and Golf Links Road.
- 5.1.5 The final CTMP and TP is expected to identify any changes to the information provided within this section. This could include changes in size of the site accesses, changes in vehicle sizes and types proposed to enter/egress the site accesses, confirmation of the AIL vehicles and routes to be used and changes in the street furniture required to be temporarily removed for the AILs to gain access to the Order limits. In addition, the final CTMP and TP will outline the layouts of the two centralised staff car parks.

5.2 Sunnica West Site A and East Sites A and B Accesses Review Summary

- 5.2.1 The proposed locations of the Sunnica West Site A and Sunnica East Sites A and B site accesses are identified previously in Section 4.
- 5.2.2 Following the Examination questions and the Local Impact Report, **Annex C** of this report has been updated with the site access drawings which are further discussed in Section 5.9.
- 5.2.3 As a result of the Change Report 2 (January 2023) this section has been updated with the removal of reference to Sunnica West Site B. The previous review of the Sunnica West Sites A and B and Sunnica East Sites A and B site accesses are available in Revision 02 of this Framework CTMP and TP [**REP3-013**].

5.2.4 Where required, the junction work areas (indicative layouts) have been considered in order to accommodate larger vehicles such as cranes and AILs on an infrequent basis at Sunnica West Site A: Access A (La Hogue Road), Sunnica East Site A: Access K (Beck Road), and Sunnica East Site B: Access A (Elms Road). These are discussed in Section 5.4 below.

5.2.5 The information above had been used to help identify the proposed site access strategy which includes Traffic Regulation Measures (temporary traffic signals and temporary speed limit reductions) **[REP6-008 to REP6-012]** where considered appropriate to provide safe entry and egress of construction vehicles. A summary of the proposed temporary traffic management is outlined in Section 6 of this report. The temporary traffic management identified within the Traffic Regulation Measures Plans (documents to be certified under the Order, if made) identify the proposed access strategy for the site accesses. The provision of the temporary traffic signals and speed limit reductions are in-lieu of providing the full visibility splays as this could result in excess vegetation loss which would be inappropriate and not in proportion to the timeframe the site accesses are proposed to be used during the construction period.

Highway Works - Elms Road and La Hogue Road

5.2.6 The below paragraphs have been updated in response to the examination question Q1.10.44.

5.2.7 The majority of the HGV movements on local roads are forecast to occur on Elms Road and La Hogue Road as these are where the main site accesses are located for Sunnica East and Sunnica West respectively. These site accesses are located 400m (0.25 miles) and 1km (0.6 miles) from the A11 respectively.

5.2.8 During consultation, SCC inquired about HGVs passing another vehicle without overrunning the verge. Therefore, a review was undertaken into the widths of key local roads including Elms Road, Newmarket Road and La Hogue Road where the majority of the HGV trips would be undertaken on the local roads.

5.2.9

5.2.10 The two indicative plans in **Annex C** (Sheet Numbers ACM-60589004-ANR-DR-0007 and ACM-60589004-ANR-DR-0020) identify where passing places can be provided to accommodate passing places of two HGVs on Elms Road and La Hogue Road. This includes consideration of the geometry of the highway and other characteristics such as the verge and vegetation as well as adequate space for wingmirrors of the two HGVs to pass one another. Therefore, demonstrating where two-way movements of HGVs can be accommodated.

5.2.11 It is also noted that condition surveys of the local highway (including PRowS) network in which on HGV routes are committed to be undertaken prior, during and after construction to identify, and subsequently make good, any damage caused. The detailed scope of the condition surveys will be agreed with the local highway authorities. Further information is provided within paragraph 7.2.15 and 7.2.16 within this document in relation to the commitment to condition surveys.

5.3 Summary of Grid Connection Route A and Grid Connection Route B Site Access Review

5.3.1 The proposed locations of the Grid Connection Route A and Grid Connection Route B site accesses are identified previously in Section 4.

5.3.2 As part of the Grid Connection Route A and Grid Connection Route B site access review, a number of accesses were adjusted or removed from the Scheme. Thus, the choice of access locations has been optimised to reduce potential impacts on the highway network.

5.3.3 The following summary is provided for the site accesses proposed for Grid Connection Route A and Grid Connection Route B.

5.3.4 A review was undertaken of the Grid Connection Route A and Grid Connection Route B site accesses' which included the following, with further information provided in **Annex C** of this report:

- Summary of the existing site access or the proposed site access location;
- Site visit photos of some of the access and views from the access;
- Swept path analysis using a 16.5m articulated lorry;
- Junction work areas (indicative layouts) showing an indicative layout of the site access junctions based on the 16.5m articulated lorry. Consideration was given to smaller vehicles where the 16.5m articulated lorry was too large to gain access, with further information provided in **Annex C** of this report;
- Visibility splays based on Design Manual for Roads and Bridges (DMRB) guidance for 60mph (100kph) roads showing a splay of 2.4m x 215m. In addition, the visibility splay was considered for the access from Anchor Lane for a 30mph speed limit with further information provided in **Annex C** of this report; and
- An alternative site access review was undertaken for Ferry Lane/Beck Road.

5.3.5 At the Grid Connection Routes A and Grid Connection Route B site accesses, hard standing surface is to be provided for the junction work areas. The new site accesses created for the Grid Connection Route A and Grid Connection Route B site accesses are not required during the operational phase of the Scheme, so these will be reinstated with the hard surfacing removed and vegetation replanted following the construction phase. The existing site accesses into the land for the Grid Connection Route will be retained for infrequent access during the operational phase. While not required to be maintained during the operational period the Applicant requires the ability to reinstate and use these accesses should it be necessary to carry out maintenance and, following the completion of such maintenance, the accesses would be removed and the land reinstated.

5.3.6 The information above had been used to help identify the proposed construction site access strategy which includes Traffic Regulation Measures Plans – Temporary Measures (which show temporary traffic signals and temporary speed limit reductions) as are considered appropriate measures to provide safe entry and egress for the construction vehicles (staff vehicles, HGVs, cranes and AILs). A

summary of the proposed traffic management arrangements are provided in Section 6 of this report.

5.4 AIL Route Reviews Summary

- 5.4.1 In addition to the site access reviews of the Sunnica West, Sunnica East and Grid Connection Route A and Grid Connection Route B, a review of the potential AIL routes from the Strategic Road Network (SRN) (A11 and A14) to the required site accesses was undertaken. AILs are abnormal indivisible loads, which include cranes and vehicles used to transport transformers.
- 5.4.2 The crane route review included swept path analysis of a 1000T, 650T and 400T crane and a 46.63m AIL to/from the following site accesses.
- 5.4.3 **Annex D** of this report provides the crane and AIL route review drawings, which are shown in **Figure 21** to **Figure 30**. The Figures produced within the body of this document are included to support the reader in their understanding of the report. They are reproduced at scale in the relevant Annexes within this document, which should be referred to aid any review of the drawing content.
- 5.4.4 **Annex G** of this report provides further information regarding the 46.63m AIL route review.
- 5.4.5 Based on the information provided by an experienced contractor, the 1000T crane was identified as the largest vehicle expected on-site¹. Included in the crane route review was a 1000T Crane (22.6m long), 650T Crane (20.6m long) and a 400T Crane (18.5m long). The cranes identified represent a range of vehicle sizes likely to be required to use the accesses. Refer to **Figures 14 to 19** for visual representations of the cranes. Additional information provided by an experienced contractor, post November 2021 DCO submission, indicates the 46.63m AIL to be the largest vehicle expected on-site, with further information provided below. Figure 20 provides a visual representation of the 46.63m AIL. The 46.63m AIL will likely have a transport weight of approximately 130 tonnes, with a maximum weight of 150 tonnes being assumed.
- 5.4.6
- 5.4.7 The route review identifies feasible routes for the cranes and AIL. A further review of the route(s) will be carried out by an experienced contractor prior to the crane(s) and AIL(s) requirement on-site. The requirements for the cranes and AILs along the routes will be discussed with the relevant local highway authorities, National Highways and police.
- 5.4.8 The swept path analysis for the cranes and 46.63m AIL route review has been based on OS mapping which is considered sufficient for this stage of the planning process. Topographical surveys will be undertaken of the routes post consent and before the movements take place.
- 5.4.9 The swept path analysis for the 1000T crane included below shows the wheel lines (in red) and the overhang/oversail of the vehicle's body (in green). The swept path

¹ The largest vehicle now expected on site is the 46.63m long Girder Trailer which is discussed in section 5.5.

analysis for the 46.63m AIL included below shows the wheel lines (in blue) and the over sail of the vehicle's body (in orange).

- 5.4.10 An overview of the crane and AIL route reviews are provided in Figure 21 and also Drawing Number 60589004_ES_CTMP_014 in Annex A of this report. The previous drawings for the route to/from the existing Burwell Substation have been removed from this version of the Framework CTMP & TP as the requirement for AILs to travel to/from Burwell has been removed as part of the Change Report 2 (January 2023).
- 5.4.11 The route review identified that there was a practical and achievable route from the Strategic Road Network (A11 or A14) to the site accesses that were required to accommodate an AIL. However, it is noted that the routes included within the review do not necessarily mean they will be the final routes of the AILs. It will be the hauliers' responsibility to finalise the AIL route in coordination with the relevant highway authorities and any other relevant authority e.g. the Police. The haulier will comply with the Government regulations that govern the movements of abnormal loads on the highway network.

1000 Tonne Mobile Crane

Used for: Transformer Installation



Typical Specification:

- Length: 22.6 M
- Width: 3.0 M
- Height: 4.0 M
- Axles: 9
- Maximum Axle Load: 13.7 Tonnes
- Weight: 123 Tonnes
- Turning Radius: 17.5 M

Figure 14 1000T Crane (22.6m)

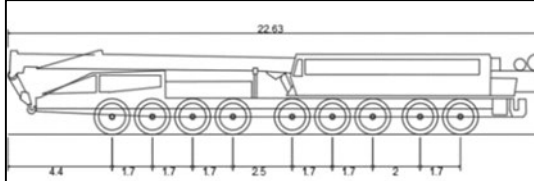

1000T Mobile Crane

- Overall Length: 22.630m
- Overall Width: 3.000m
- Overall Body Height: 3.536m
- Min Body Ground Clearance: 0.740m
- Track Width: 3.000m
- Lock to lock time: 5.00s
- Wall to Wall Turning Radius: 17.500m

Figure 15: Swept Path Analysis – Vehicle Profile – 1000T Crane (22.6m)

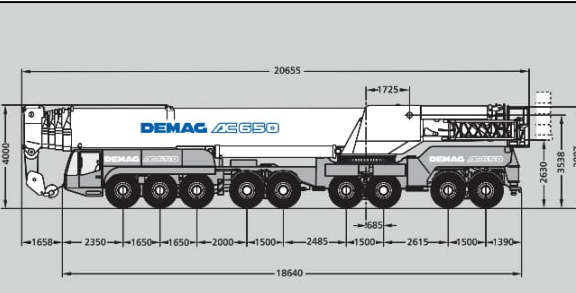
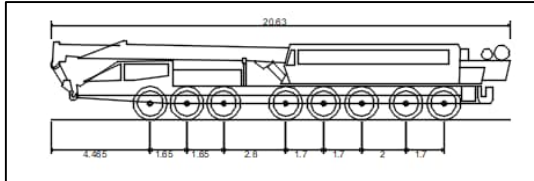

Figure 16: 650T Crane (20.6m)



650T Mobile Crane

- Overall Length: 20.630m
- Overall Width: 3.000m
- Overall Body Height: 3.536m
- Min Body Ground Clearance: 0.740m
- Max Track Width: 3.000m
- Lock to lock time: 5.00s
- Wall to Wall Turning Radius: 16.500m

Figure 17: Swept Path Analysis – Vehicle Profile – Crane (20.6m)

400 Tonne Mobile Crane

Used for: Electrical Equipment Installation (e.g. Battery Modules)



Typical Specification:

- Length: 18.5 M
- Width: 3.0 M
- Height: 4.0 M
- Axles: 7
- Maximum Axle Load: 12 Tonnes
- Weight: 84 Tonnes
- Turning Radius: 15.7 M

Figure 18: 400T Crane (18.5m)

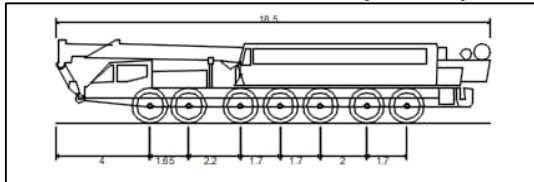

400T Mobile Crane

- Overall Length: 18.500m
- Overall Width: 3.000m
- Overall Body Height: 3.536m
- Min Body Ground Clearance: 0.740m
- Track Width: 3.000m
- Lock to lock time: 5.00s
- Wall to Wall Turning Radius: 15.700m

Figure 19: Swept Path Analysis – Vehicle Profile – 400T Crane (18.5m)

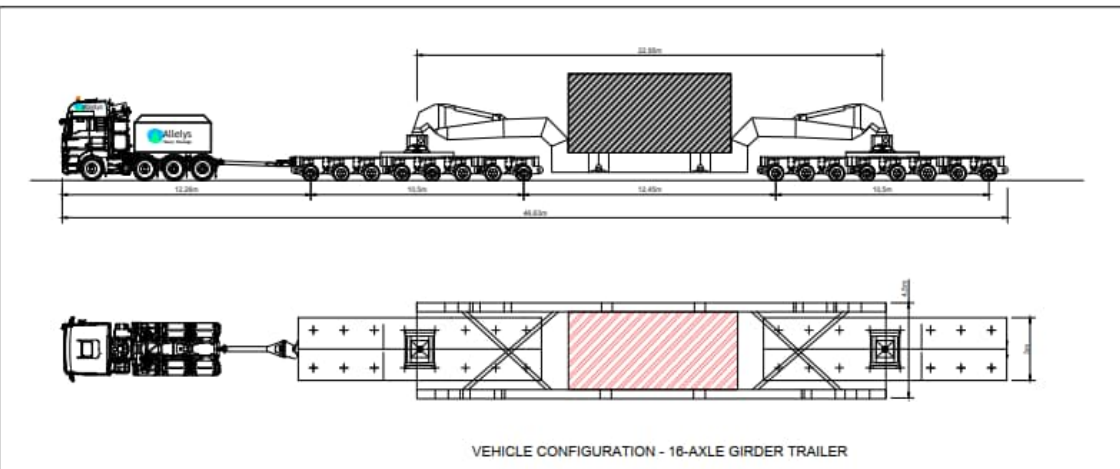

VEHICLE CONFIGURATION - 18-AXLE GIRDER TRAILER

Figure 20: Swept Path Analysis – Vehicle Profile – AIL (46.63m)

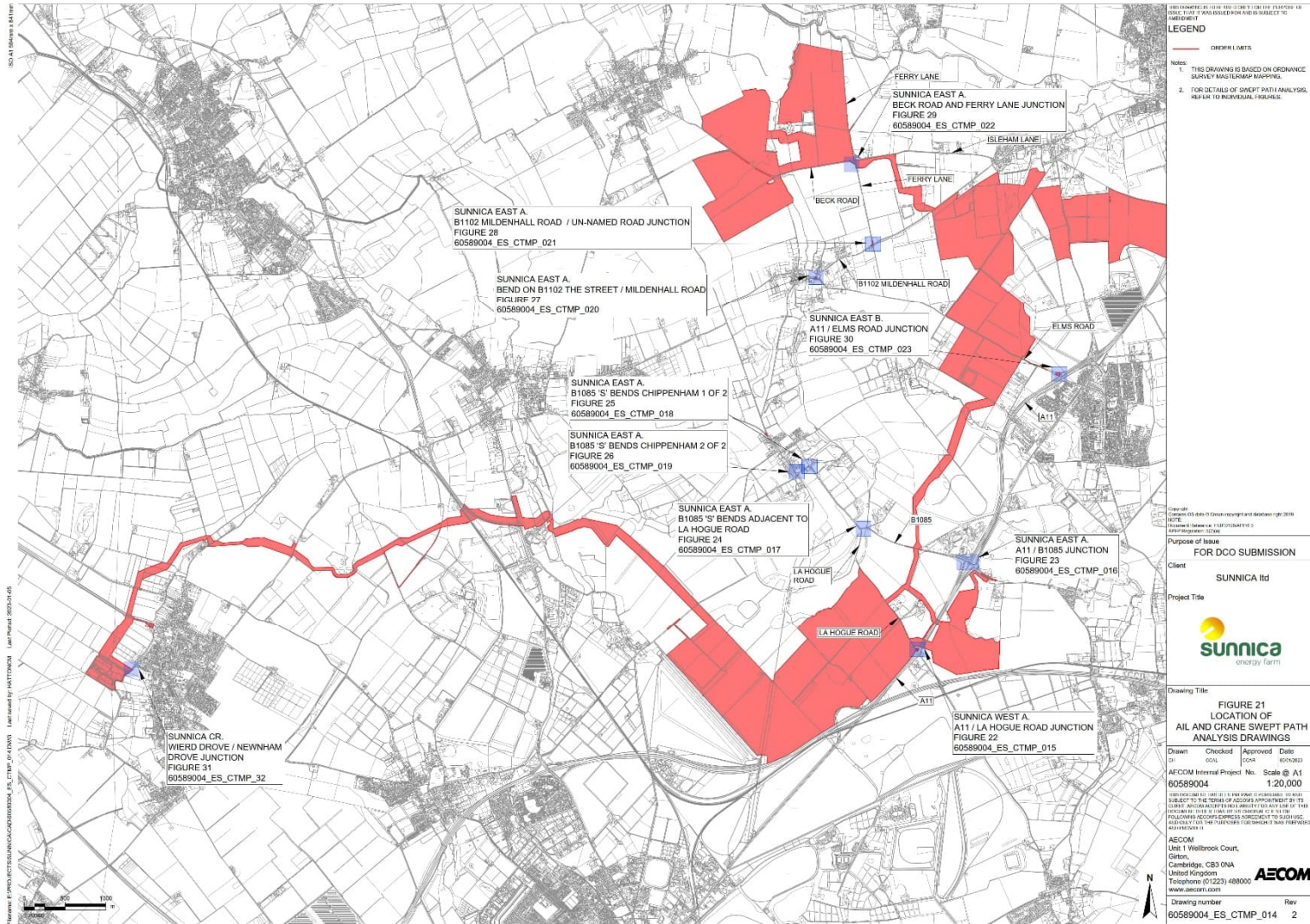

Figure 21: Overview for Crane and AIL Route Reviews

5.5 Sunnica West Site A – La Hogue Road

5.5.1 The nearest part of the SRN to La Hogue Road site access is the A11 via the A11 northbound off-slip/northbound on-slip/La Hogue Road junction. A summary of the route between the A11 and the site access on La Hogue Road is provided below:

- The La Hogue Road site access is located a short distance from the A11 northbound off-slip which requires the vehicles to turn left from the A11 onto La Hogue Road on entry and left turn from La Hogue Road onto the A11 on egress. The swept path analysis for the 1000T crane and 46.63m AIL are shown in Figure 22 below and Drawing Number 60589004_ES_CTMP_015 in Annex A. The swept path analysis shows that the crane wheel paths will remain within the carriageway, but the body of the crane will overhang the central island. This will not result in conflict with pedestrians, however entry for the 1000T crane requires the temporary removal of the traffic signage within the central island at the A11/La Hogue Road slip road junction. This is not required for the 650T or 400T cranes. The swept path analysis has shown that the 46.63m AIL can safely manoeuvre the A11 / La Hogue Road junction; however, the trailer will over sail the inside grass verge of the junction by approximately 3.2m but will remain within the bounds of the highway and require a street sign to be temporarily removed or relocated.
- On egress, there is also the requirement for traffic signage to be temporarily removed for the 1000T crane, with the swept path analysis shown in Figure 21 below and Drawing Number 60589004_ES_CTMP_015 in Annex A. However, the removal of the road sign is not required for the 650T or 400T cranes. The 46.63m AIL will be disassembled once delivery of the 400KV transformer has taken place, meaning that swept path analysis of the egress movement is not required. The short-term temporary removal of street signage is not considered to be a concern to the operation of this junction and signage will be promptly re-instated.
- If required, the cranes can manoeuvre at the Red Lodge Dumbbell Roundabouts to make a U-turn as identified in the Sunnica East Site B (Elms Road) summary in order to travel southbound on the A11.



Figure 22: Swept Path Analysis – 1000T Crane and 46.63m AIL – A11 / La Hogue Road Junction

5.6 Sunnica East Site A – Ferry Lane and Beck Road

- 5.6.1 Various routes were initially considered for the cranes and AILs between the SRN and Sunnica East Site A: Site Access E on Ferry Lane (Freckenham Road USRN: 14601046). Initial investigation was for the crane(s) to access the site via the existing access on Ferry Lane (Freckenham Road USRN: 14601046), A summary is provided below.
- Route 1 via the B1085 (High Street) through Chippenham B1104 and B1102 Fordham Road through Freckenham to Ferry Lane (Freckenham Road USRN: 14601046);
 - Route 2 via the Red Lodge Dumbbell Roundabouts and via Newmarket Road and Mildenhall Road through Worlington and Isleham Road to Ferry Lane (Freckenham Road USRN: 14601046); and
 - Route 3 via Elms Road, Church Lane through Freckenham, B1102 (Mildenhall Road) and to Ferry Lane (Freckenham Road USRN: 14601046).
- 5.6.2 A route via the A1101 Kingsway through Mildenhall and B1102 Worlington Road was also considered and discounted at this stage so as to avoid disruption through Mildenhall and following a high-level consideration of the potential highway constraints.
- 5.6.3 The primary concern with Route 1 was the weight limited bridge on Ferry Lane (Freckenham Road USRN: 14601046) adjacent to the Isleham Road and Beck Road junction. Therefore, alternative routes were investigated if the weight of the cranes were too heavy for the bridge. Route 2 identified that the cranes and AILs were unable to manoeuvre the Newmarket Road/Mildenhall Road T-Junction in Worlington. As a result, a third route was investigated via Elms Road and Church Lane through Freckenham. This identified that the cranes and AILs were unable to manoeuvre the Elms Road/Church Lane T-Junction.
- 5.6.4 Following discussions with the Historic Railway Estate on behalf of Department for Transport, it was confirmed the weight limit of the bridge on Ferry Lane (Freckenham Road USRN: 14601046) is 44 tonnes. Therefore, prior to the submission of the DCO Application, it was considered necessary to identify an alternative site access which could be accessed by avoiding the bridge for large vehicles such as the cranes and AILs
- 5.6.5 Following the initial review, an additional review of the site access options for the cranes for the Ferry Lane (Freckenham Road USRN: 14601046) site access was undertaken. This identified two alternative options via Beck Road. A summary is provided below:
- Alternative option 1 is located on Beck Road which is a two-way road with a national speed limit (60mph). The existing access to the farm consists of hard surfacing (tarmac) with gates and a brick wall on both sides of the access road; and
 - Alternative option 2 is located on Beck Road approximately 320m to the east of option 1. There is an existing farm access with a gap in the hedgerow connected to an internal track which runs in a north-south direction. The existing site access is narrow and is an unmade access

which is bounded by hedgerow on either side. This access, approximately 4.0m to 4.5m wide, is used by agricultural vehicles to access the farmland.

- 5.6.6 Investigation into the two alternative site access options on Beck Road identified that the cranes and AILs were unable to manoeuvre via option 1 through the existing gated access without removing the gates and part of the existing brick wall. Therefore, the existing agricultural access on Beck Road (alternative option 2) has been identified as the preferred site access for the cranes and AILs as there is an existing gap in the hedgerow and the site access will provide emergency access during the operational phase. The HGVs are to use the existing site access identified on Ferry Lane (Freckenham Road USRN: 14601046).
- 5.6.7 As a result of the route review for the cranes, the swept path analysis for the 46.63m AIL has been undertaken for the final route from the A11 to Beck Road. Figure 23 to Figure 29 identify the swept path analysis for the 1000T crane and 46.63m AIL along the route from the A11, which are also provided in Annex A from Drawing Number 60589004_ESE_CTMP_016 to 60589004_ESE_CTMP_022 and is summarised below.
- 5.6.8 Figure 23 at the A11 off-slip / B1085 Junction shows that the AIL trailer will over sail the inside grass verge by approximately 2.5m but will remain within the bounds of the highway and no temporary alterations to streets are considered necessary to facilitate this manoeuvre. The 1000T crane can manoeuvre the junction within the carriageway. In addition, the egress movement for the 1000T crane is shown at the Dane Hill Roundabout accessing the A11 southbound.
- 5.6.9 Figure 24 at the 'S'-Bend on B1085 shows that the AIL trailer will over sail the inside grass verge by approximately 2.1m at Low Park Corner along the B1085 but will remain within the bounds of the highway and no temporary alterations to streets are considered necessary to facilitate this manoeuvre. The 1000T crane can manoeuvre the turns within the carriageway.
- 5.6.10 Figure 25 and Figure 26 shows that at the 'S' bends on B1085 Chippenham the AIL trailer will over sail the inside grass verge by approximately 1.2m but will remain within the bounds of the highway and no temporary alterations to streets are considered necessary to facilitate this manoeuvre. The 1000T crane can manoeuvre the turns within the carriageway.
- 5.6.11 Figure 27 shows that at the bend on the B1102 The Street / Mildenhall Road junction (which is identified on sheet 21 of the ARoW Plans as AS-36): vegetation clearance (branch trimming) of the tree located within the centre of the junction may be required to allow AIL to navigate the junction but the vehicle will remain within the bounds of the highway. The 1000T crane can manoeuvre the junction bends the carriageway.
- 5.6.12 Figure 28 shows that at the B1102 Mildenhall Road/Ferry Lane (Freckenham Road USRN: 14601046) junction (which is identified on sheet 21 of the ARoW Plans as AS-37) the AIL trailer will over sail the inside verge by approximately 4.3m and over sail private land. This will require the existing private fence/gate to be removed or relocated as well as some minor vegetation clearance to facilitate the manoeuvre. The Order Limits have been adjusted (via the first changes application) to facilitate

the over sail at this location. The 1000T crane can manoeuvre the junction within the carriageway with the body slightly overhanging the verge at the junction.

- 5.6.13 Figure 29 shows that at the Beck Road / Ferry Lane (Freckenham Road USRN: 14601046) junction (which is identified on sheet 4 of the ARoW Plans as AS-5) the AIL trailer will over sail the inside verge by approximately 2m. This will require the temporary removal or relocation of two existing road signs. There may also be a requirement to clear vegetation (branch trimming) to facilitate access, but the vehicle will remain within the bounds of the highway. The 1000T crane can manoeuvre the junction within the carriageway.

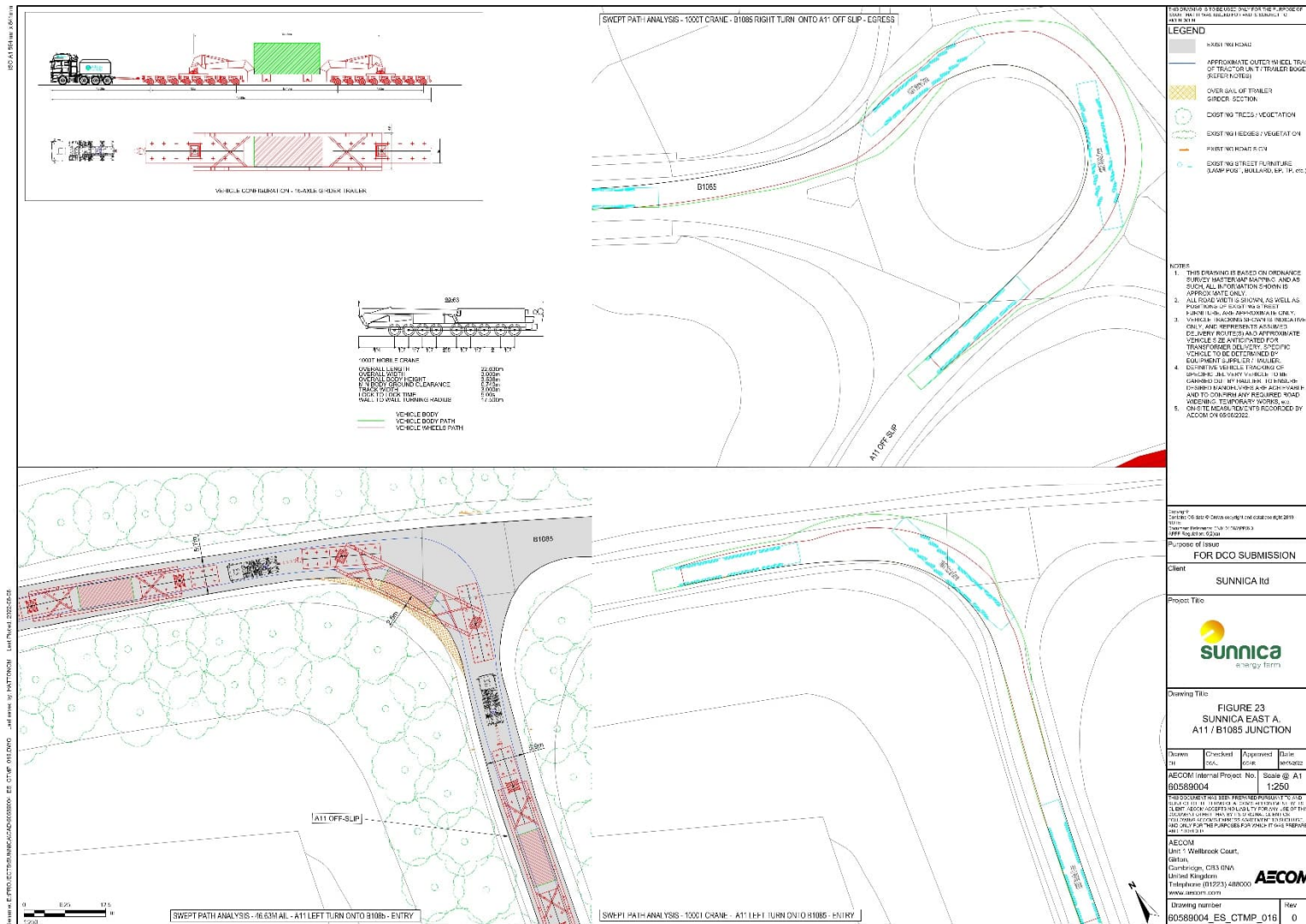

Figure 23: Swept Path Analysis – 1000T Crane and 46.63m AIL – A11 / B1085 Junction

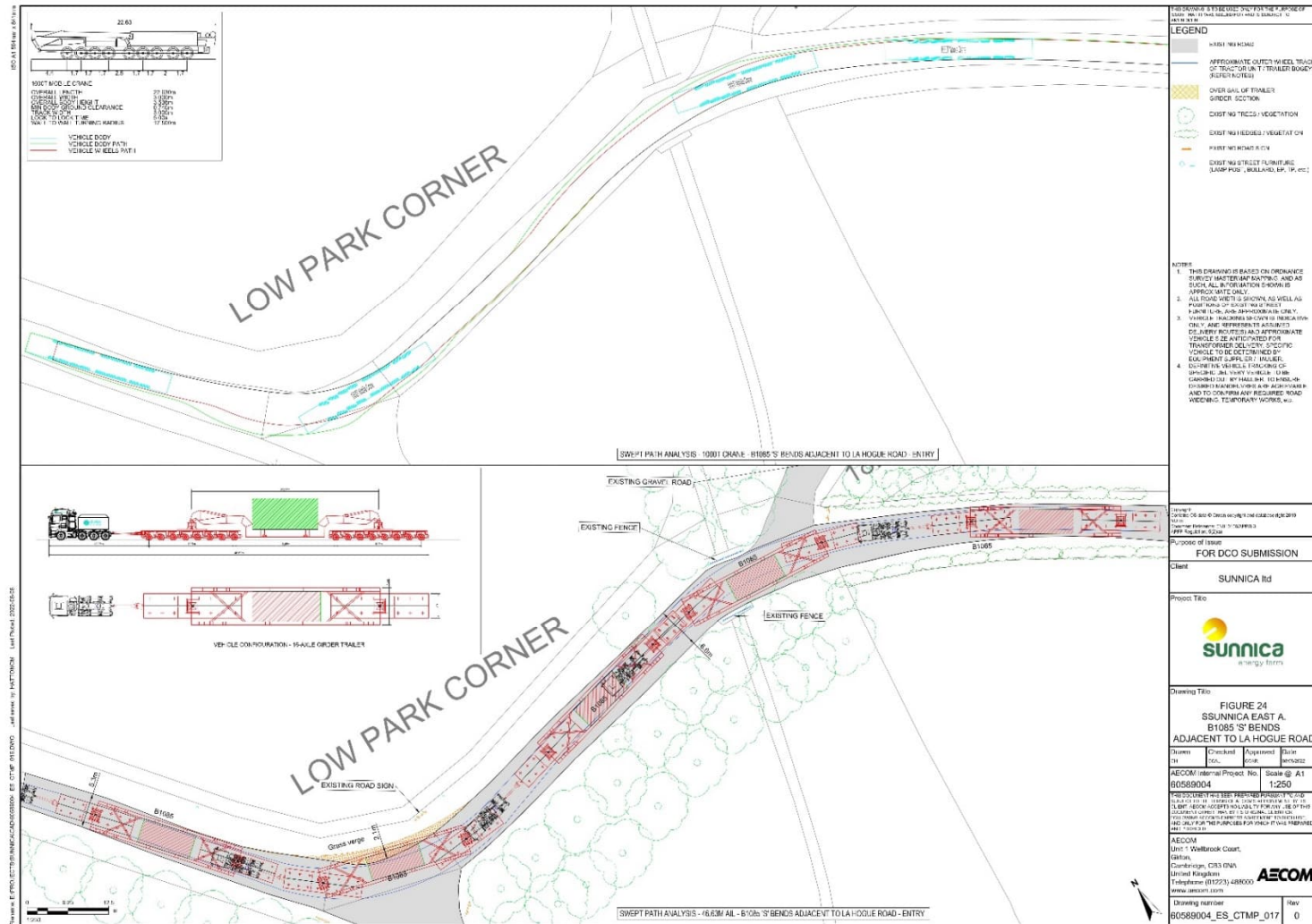

Figure 24: Swept Path Analysis – 1000T Crane and 46.63m AIL – B1085 ‘S’ Bends adjacent to La Hogue Road Junction

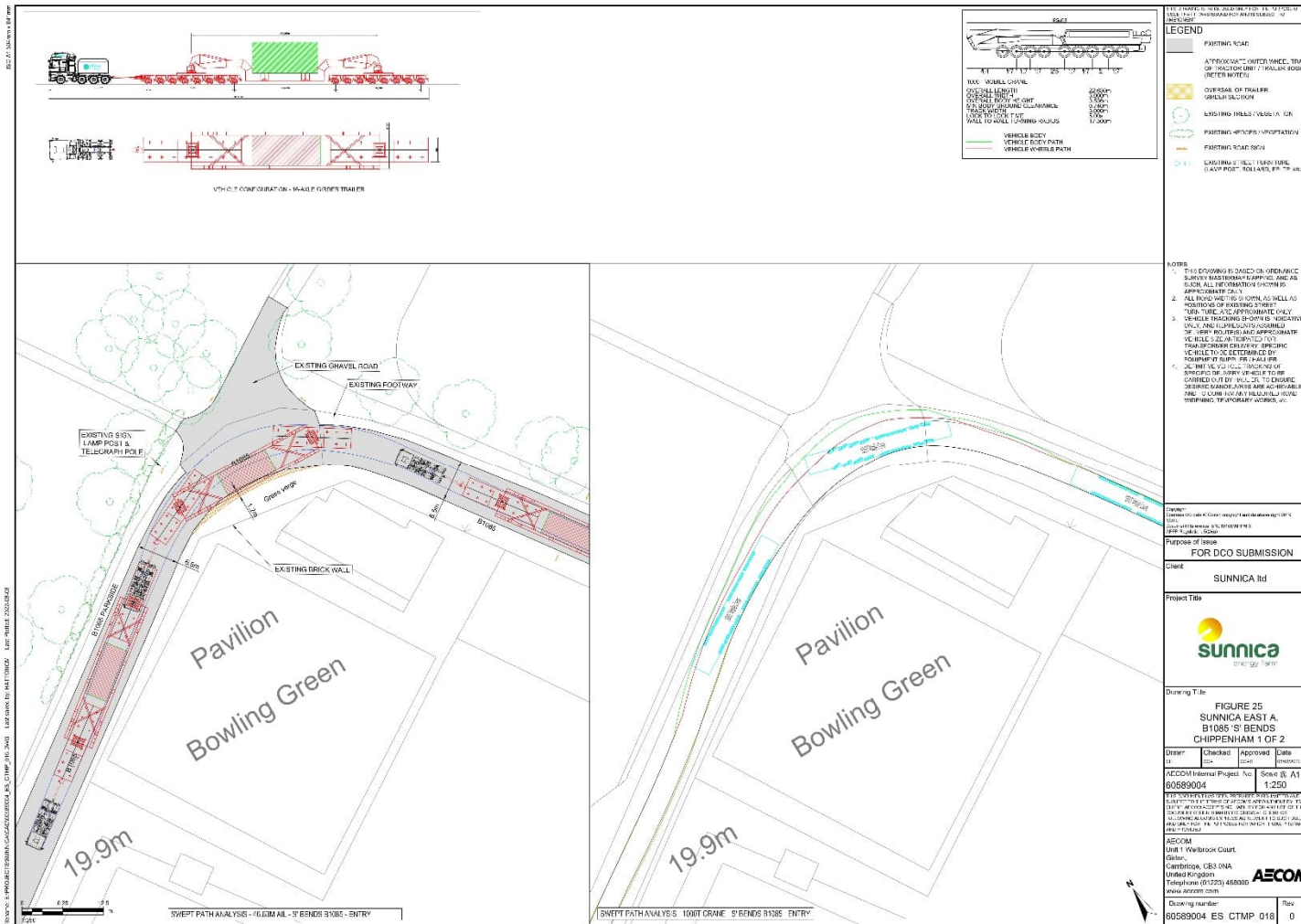

Figure 25: Swept Path Analysis – 1000T Crane and 46.63m AIL – B1085 'S' Bends Chippenham (1 of 2)

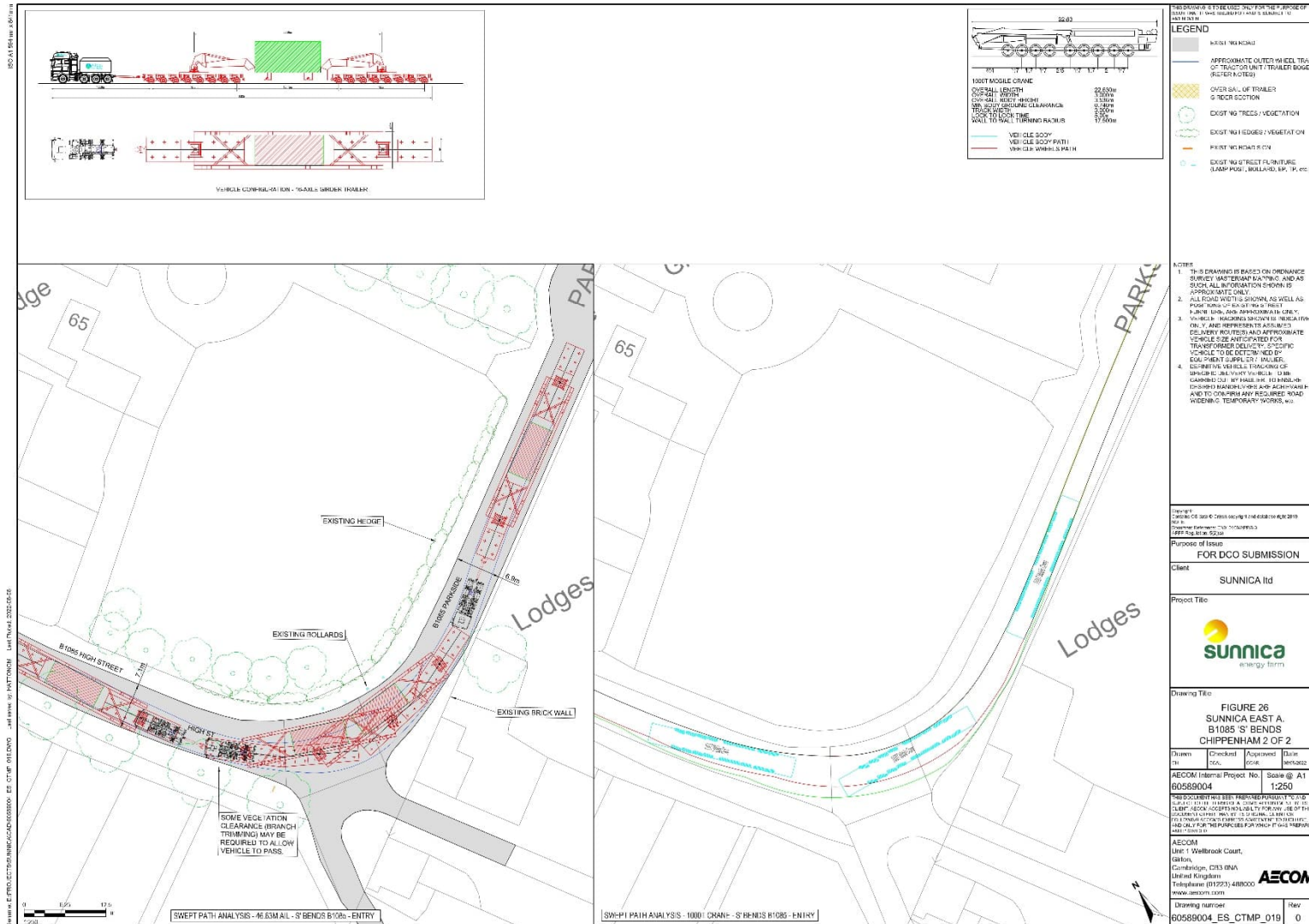

Figure 26: Swept Path Analysis – 1000T Crane and 46.63m AIL – B1085 ‘S’ Bends Chippenham (2 of 2)

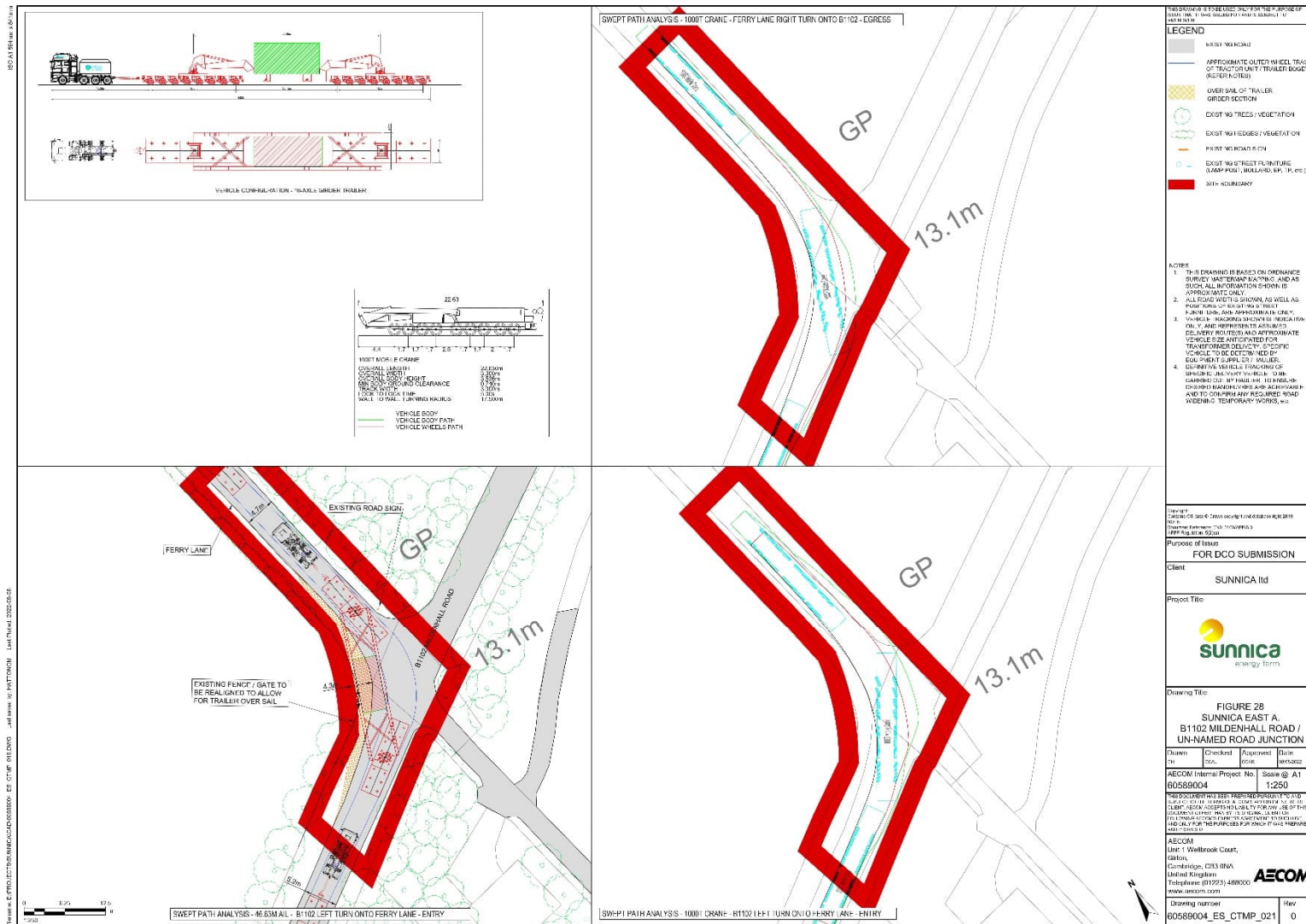

Figure 28: Swept Path Analysis – 1000T Crane and 46.63m AIL – B1102 Mildenhall Road / Ferry Lane Junction

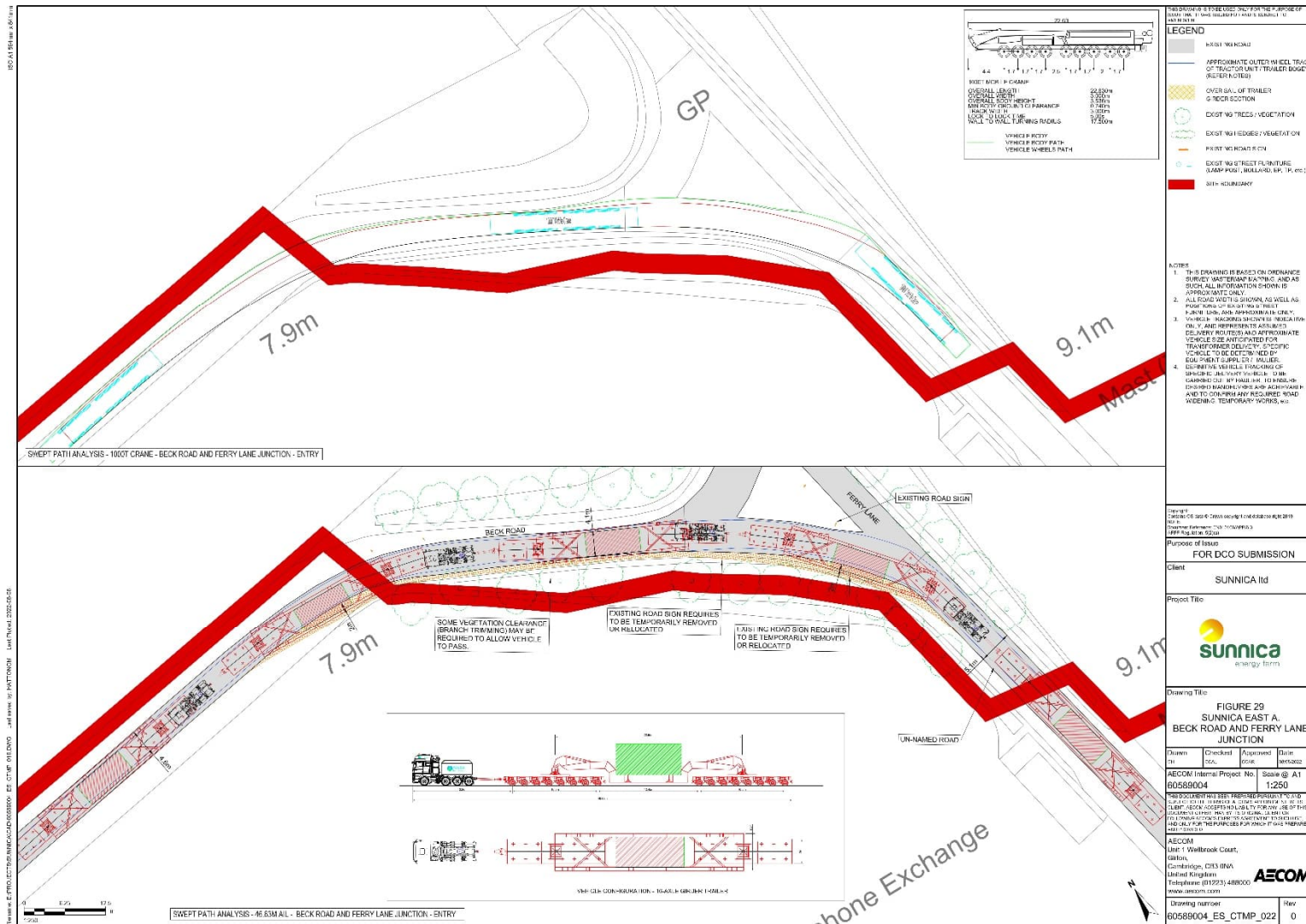

Figure 29: Swept Path Analysis – 1000T Crane and 46.63m AIL – Beck Road / Ferry Lane Junction

5.7 Sunnica East Site B – Elms Road

5.7.1 The nearest part of the SRN to Elms Road site access is the A11 via the A11 northbound off-slip/Elms Road T-Junction (entry) or the Red Lodge Dumbbell Roundabouts (egress). A summary of the routes is provided below which includes movements from the A11 Northbound Off-Slip/Elms Road Junction and discussion regarding the Red Lodge Dumbbell roundabouts:

- All three cranes can manoeuvre the A11 northbound off-slip/ Elms Road T-Junction, with the swept path analysis shown in Figure 30 for a 1000T crane. There is the potential with the 1000T crane on entry that the temporary removal of a nearby road sign on Elms Road could be required which will need to be confirmed prior to the crane being required on-site. This is not considered to be a significant constraint to using this junction. Any signage temporarily removed is to be promptly reinstated.
- The swept path analysis has shown that the AIL can safely manoeuvre the A11 / Elms Road junction. However, the trailer will over sail the inside grass verge of the junction by approximately 3.4m and require a street sign to be temporarily removed or relocated but the vehicle will remain within the bounds of the highway, as illustrated in Figure 30.
- All three cranes can manoeuvre the Red Lodge Dumbbell Roundabouts on egress and if required on entry. The 46.63m AIL will be disassembled once delivery of the 400KV transformer has taken place, meaning that swept path analysis of the egress movement is not required.



Figure 30: Swept Path Analysis – 1000T Crane and 46.63m AIL – A11 Northbound Off-Slip/Elms Road Junction

5.8 Burwell National Grid Substation Extension

- 5.8.1 AIL and Crane access will not be required to Burwell National Grid Substation as the January 2023 Change Report 2 removes the need for a substation extension in this location. Therefore Swept Path Analysis of these movements has been removed from this Framework CTMP/TP.
- 5.8.2 Notwithstanding this, works will still be required to construct Grid Connection Route B to facilitate connection of the Scheme to the national electricity grid at Burwell. Therefore, access at Cable Route Access B would be retained for those works and for maintenance during operations. Thus HGV access will be required.
- 5.8.3 Widening was previously proposed to Newnham Drove, including the junction with Weirs Drove, to accommodate the passage of AILs. Swept Path Analysis of an HGV undertaking these routes has been undertaken to determine any residual widening required. It has been determined that a lesser degree of widening at the junction of Newnham Drove/Weirs Drove is required, and no widening is required elsewhere on Newnham Drove. This is shown in Figure 31.

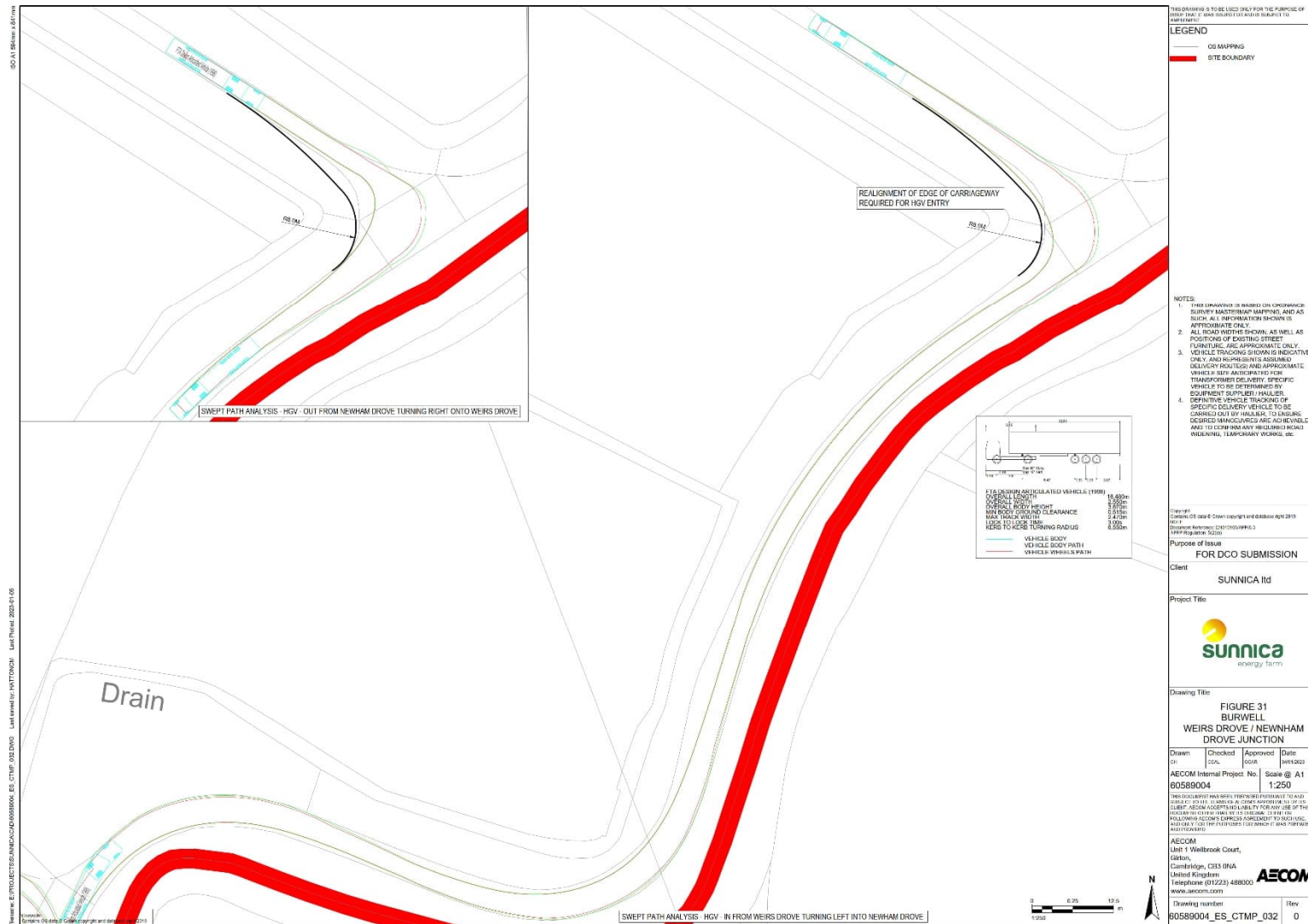

Figure 31: Swept Path Analysis – HGV – Weirs Drove / Newnham Drove Junction

5.9 Summary of Site Accesses

5.9.1

5.9.2 This section of the report summarises the information provided in the site access drawings, as shown in **Annex C**.

5.9.3 As a result of the update to **Annex C**, the previous information provided in this summary has been superseded but can be found in the previous iterations of this document [**REP3-013, REP5-015**].

5.9.4 The site access drawings in Annex C are indicative only. They represent the Applicant's current intentions for the layout of accesses relevant to this Scheme. The drawings have a sufficient level of detail for the site access proposals (e.g. measurements / distances etc.), to demonstrate feasibility of safe and suitable access. These proposals will be refined at detailed design stage and submitted for approval in accordance with the protective provisions for the benefit of local highway authorities contained in the DCO.

5.9.5 Where relevant, the following information has been included on the site access drawings in **Annex C**:

- Location and intended use in construction, operational and / or decommissioning phases;
- Scale provided on each individual drawing;
- North arrow on each individual drawing;
- Identified if the base mapping is either topographical or Ordnance Survey (OS) on each individual drawing;
- On-site measurements recorded during site visit;
- Swept path analysis for vehicle types including large cars, HGVs, a 1000T crane and a 46.63m AIL;
- Indicative site access layouts including dimensions;
- Visibility splay for the main staff access during the operational period;
- Summary of the site access use during the construction period in terms of HGVs;
- Reference made to the Traffic Regulation Measures Plans – Road Closures and Temporary Traffic Regulation Measures Plans - Temporary Measures) [**REP6-008 to REP6-012**];
- Summary of the proposed temporary traffic signals and the achievable visibility splay during the use of the temporary traffic signals;
- Vegetation clearance at the site accesses;
- the Order limits; and
- Identified Highway Works on Elms Road and La Hogue Road to accommodate two-way HGV movements.

5.9.6 There are various key points to note in relation to the site access drawings:

- a. Not all drawings necessarily have the same amount and level of information presented. This is dependent on the complexity of the relevant site access in terms of e.g. the amount of works required, any swept path analysis needed to demonstrate how it will function etc. The implication of this is that certain site accesses are shown across more than one sheet.
- b. Consistent Keys are used across the drawings. Where something is included on the Key, and not shown within the drawings, this is not an omission of information from the plan. The set of drawings for each access does not include all information on the same sheet for clarity of presentation, only the key information required to be understood by the reader for the relevant sheet. Thus the Order limits are shown where relevant, but not necessarily on each and every sheet / segment of sheet.
- c. Land ownership boundary information from His Majesty's Land Registry has been used for the purpose of identifying interests in the land contained within the Order limits.
- d. The draft DCO gives the Applicant the power to undertake necessary works within both the highway and on private land, where it is included within the Order limits. Where there is AIL tracking, where it has been identified for this purpose to undertake works at relevant junctions, it is ensured that these works are within the Order limits.
- e. On-site measurements have been used to verify the accuracy of OS mapping at several site accesses and no inaccuracies were identified. A further site visit was undertaken in August 2022 to review the site accesses when the vegetation is considered to be at its most prevalent. Information resulting from the highway measurements undertaken during the site visit are provided on the site access drawings at **Annex C**.
- f. Where no works are currently expected at a site access, there are no site access drawings provided within **Annex C** of this document for that location. This includes:
 - i. a site access on Beck Road (SE-G) which is an existing access and is required to access the ecological and heritage mitigation areas (ECO1 and ECO2) within Sunnica East A. Vehicles are required to access this location. However, these are anticipated to be LGVs and vehicles similar to those that currently utilise the access such as farm machinery to maintain this area.
 - ii. the site access on Golf Links Road (SE-J), which is an existing access to the land and is retained as a means of access. There will be no intensification of this site access during the operational phase as it will be used for infrequent maintenance.
- g. The likely significant environmental effects of vegetation clearance and drainage at site accesses has been considered within the Environmental Statement at Chapter 8 [**APP-040**] and Chapter 9 [**APP-041**]. The extent of the vegetation clearance required at site accesses has also been highlighted on the site access drawings.

5.10 Indicative Staff Car Park Layouts

5.10.1 The indicative layouts of the two centralised car parks for Sunnica West and Sunnica East are identified in **Figure 32** and **Figure 33** respectively. The indicative car park layouts shown they can accommodate the forecast individual staff vehicle peaks which demonstrates how the car parks layout could be achieved with the final car park layout to be provided in the final CTMP and TP which would be required to be approved following grant of consent, in accordance with the DCO's requirements. The brown lines in the figures below represent the internal tracks. The staff car parks will reduce in size and capacity as the construction progresses and the demand for staff and staff vehicles decreases.

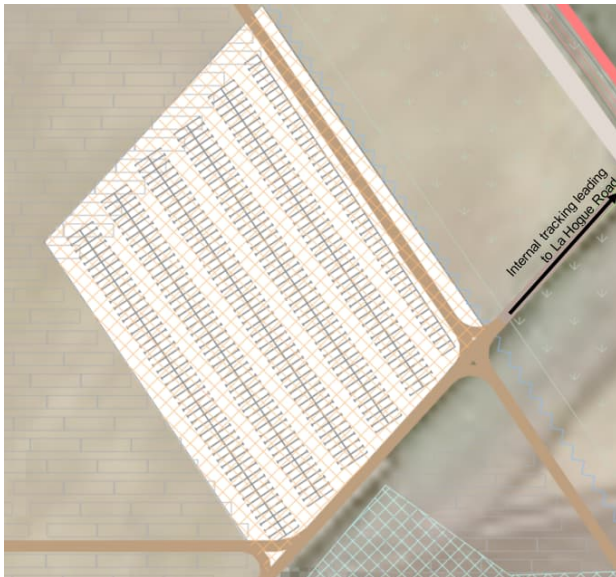

Figure 32: Indicative Car Park Layout – Sunnica West (La Hogue Road)



Figure 33: Indicative Car Park Layout – Sunnica East (Elms Road)

5.11 Stage 1 Road Safety Audit

Overview

- 5.11.1 Within the PEI Report that supported the Applicant's statutory pre-application consultation, a site access was identified on Golf Links Road with the HGV route identified via Newmarket Road which avoided the A11/Newmarket Road Junction. However, during the statutory pre-application consultation concerns were raised regarding HGVs travelling along Golf Links Road. As part of the site access review, alternative site access locations were investigated. The preferred alternative site access option located on Newmarket Road between the A11 and Golf Links Road was discussed with National Highways regarding development related vehicles using the A11/Newmarket Road Junction. It was agreed with National Highways that development related vehicles would be permitted to undertake left in and left out movements and would be prohibited to undertake right-in and right-out movements at the A11/Newmarket Road junction.
- 5.11.2 The site access on Newmarket Road between the A11 and Golf Links Road is forecast to need to accommodate an average of between 9-12 HGVs (18-24 movements) daily for the first five months of the 13-month construction period. The forecast HGVs reduce to between 2-3 HGVs (4-6 movements) daily for months six to thirteen.

Stage 1 RSA Summary

- 5.11.3 During discussions with SCC in August 2021 regarding the proposed relocation of the Golf Links Road site access to Newmarket Road located between the A11 and Golf Links Road, SCC stated that they would expect a Stage 1 RSA to be completed for an access close to a major junction. As a result, a Stage 1 RSA was undertaken.
- 5.11.4 The Stage 1 RSA was undertaken by experienced road safety auditors who are separate from and independent to the project team and other than the Stage 1 RSA have had no other involvement in the Application.
- 5.11.5 The Stage 1 RSA only identified one "problem" to be addressed. A summary is provided below with the full report provided in **Annex E** of this report.
- Summary: Slow moving HGVs turning from access may be at risk of being struck by northbound vehicles on Newmarket Road.
 - The proposed construction access is located close to the A11(T) junction. Construction turning right out of the site will do so relatively slowly and vehicles heading north on Newmarket Road, having turned from the A11 may collide with the slow turning construction vehicles.
 - Recommendation: Although it is acknowledged that the RSA brief states that warning signs are proposed along Newmarket Road warning motorists of the site access and HGVs turning, it is recommended that, at detailed design stage, a suitable clear warning signage strategy is designed (and reviewed as part of the Stage 2 Road Safety Audit) to ensure that drivers joining Newmarket Road from the A11 are aware of the construction access and potential for slow turning vehicles ahead. It is advised that the signage is provided as a 'gateway' on entry to Newmarket Road so that it is clearly seen by both right turning and left turning traffic from the A11.

- 5.11.6 In line with the recommendations made in the Stage 1 RSA, it is proposed that appropriate signage is provided as a 'gateway' on entry to Newmarket Road to warn both right and left turning vehicles of the construction site access.
- 5.11.7 Further information regarding the Stage 1 Road Safety Audit is provided below in response to the Local Impact Report.
- 5.11.8 The Stage 1 Road Safety Audit was undertaken at the request of the local highway authority. The Stage 1 Road Safety Audit was undertaken and is compliant with DMRB GG119. A summary of the Stage 1 Road Safety Audit is provided in chapter 5 of this document. The issue identified with the Stage 1 Road Safety Audit relates to slow moving HGVs turning from the site access and vehicles travelling northbound on Newmarket Road. The recommendation was to provide warning signs along Newmarket Road to warn motorists of the site access and HGVs turning. It was recommended at the detailed design stage a suitable clear warning signage strategy is designed to ensure that drivers joining Newmarket Road from the A11 are aware of the construction access and potential for slow turning vehicles. It is also advised that the signage is provided as a 'gateway' on entry to Newmarket Road so that it is clearly seen by both right turning and left turning traffic from the A11. The Applicant is committed to the recommendation. A speed survey was carried out at the request of the local highway authority which recorded the speed of vehicles at the proposed construction site access. The results of the 85th percentile are presented in Table 6-1 within this document. This identified the northbound 85th percentile vehicles speeds to be 25mph. Therefore, the desirable minimum stopping sight distance to be 70m in Design Manual for Road and Bridges (DMRB) CD109 Table 2.10. The Stage 1 Road Safety Audit identified a signage strategy to be provided warning motorists of the upcoming site access which the Applicant has commented to providing. It is also noted that National Highways agreed to the use of the A11/Newmarket Road junction for development related vehicles (left in and left out only). Therefore, it is considered the achievable visibility without vegetation trimming, the design of the site access to accommodate two-way HGV movements and the provision of the signage strategy as identified in the Stage 1 Road Safety Audit to be appropriate for this site access during the construction phase.

6 Summary of Traffic Management Proposals and Summary of Speed Surveys

6.1 Introduction

- 6.1.1 This section summarises the proposed traffic management which includes temporary road closures, temporary P_{RoW} closures, temporary traffic signals and temporary speed limits. The temporary traffic management proposals are shown on the Traffic Regulation Measures Plans – Temporary Measures and the Traffic Regulation Measures Plans – Road Closures which identify the proposed access strategy for the site accesses. The provision of the temporary traffic signals and speed limit reductions are in-lieu of providing the full visibility splays as this could result in excess vegetation loss which would be inappropriate and not in proportion to the timeframe the site accesses are proposed to be used during the construction period.
- 6.1.2 The draft DCO includes a requirement for the Framework CTMP and TP to be developed into a final CTMP and TP (either as a combined document or as separate documents) that would be submitted for the approval of the relevant County authority (or authorities) before construction is begun. The DCO, would therefore, secure that its measures are complied with. Therefore, this section is expected to be updated within the final CTMP and TP if any of the proposals outlined in this section were to change.
- 6.1.3 The proposed traffic management is shown on the Traffic Regulation Measures Plans – Temporary Road Closures and Traffic Regulation Measures Plans – Temporary Measures **[REP6-008 to REP6-012]** which accompany the DCO Application. A summary of the temporary road closures, P_{RoW} closures, traffic signals and speed limit reductions are provided in this section.
- 6.1.4 The proposed traffic management measures summarised below are to occur at different and various time periods throughout the construction of the Scheme. However, notwithstanding this, there could be more than one temporary road closure or temporary P_{RoW} closure occurring at the same time.
- 6.1.5 During consultation with SCC and CCC, in August 2021, the temporary traffic management was discussed. SCC and CCC indicated that they would expect to see speed surveys carried out wherever there was intention to change the speed limit. Firstly, this was to confirm that it was actually necessary to change the speed limit and secondly to identify if existing speeds were significantly higher than the proposed speed reductions. Therefore, as a result, speed surveys were undertaken. Vehicle speeds are unlikely to be affected to the extent that traffic flow volumes have been affected during the Coronavirus Pandemic, and therefore speed survey data collection has been feasible, as agreed with the LHAs.
- 6.1.6 The speed surveys in Suffolk were undertaken for seven consecutive days between 28th September 2021 to 5th October 2021 while the speed surveys in Cambridgeshire were undertaken between 18th to 24th October 2021. A further speed survey was undertaken at Newmarket Road between Sunnica East Site Access I and the junction with the A11. This was carried out between 20th February 2023 and 26th February 2023.

6.1.7 The purpose of the temporary traffic signals and speed limit reductions for individual site accesses during the construction phase is to provide safe access and egress for HGVs in/out of the site access. The temporary traffic signals and speed limit reductions are applied where the full visibility splay was unable to be achieved without significant vegetation trimming or removal. Appropriate warning signage will be provided on the approaches to the temporary traffic signals which will assist in reducing vehicles speeds past the site accesses.

6.2 Summary of Speed Surveys

6.2.1 The speed data has been collected using Automatic Traffic Counters (ATCs). The average and 85th percentile 12-hour weekday (Monday to Friday 07:00-19:00) speeds has been summarised in Table 6-1. The development HGVs are forecast to occur Monday to Friday between 07:00 and 19:00. The speed surveys were carried out in locations of generally free-flowing traffic and as a result it is unlikely the inclusion of peak hour speed data would reduce the average and 85th speeds significantly. Using the 12-hour average and 85th percentile speeds provides a more comprehensive representation of vehicle speeds where the site accesses are located while they are in use. All the roads identified in the table below are national speed limit (60mph). The raw speed survey data is provided in **Annex F** of this report.

6.2.2 The proposed reduced speed limits are temporary in nature, cover a short distance, will be accompanied with appropriate warning signage and will be introduced in combination with temporary traffic signals. The purpose of the temporary speed limits is to provide safe entry and egress of the site accesses for the construction vehicles. The proposed temporary speed limits are discussed further in Section 6.4.

Table 6-1: Summary of Speed Surveys: Average and 85th Percentile (mph)

Roads	Northbound/ Eastbound		Southbound/ Westbound		Proposed Temporary Speed Limit
	Average	85 th Percentile	Average	85 th Percentile	
Weirs Drove	18.7	22.1	18.7	22.3	-
B1102 Ness Drove	53.3	59.5	55.4	62.4	40mph
Newmarket Road (North of the A142 Roundabout)	46.0	53.3	44.9	52.1	40mph
Snailwell Road / Fordham Road	28.9	32.6	30.5	34.1	²
Chippenham Road (West)	44.2	50.8	42.7	49.6	40mph
Chippenham Road (East)	48.5	55.7	47.4	54.4	
La Hogue Road	43.1	51.3	44.0	51.2	40mph
Dane Hill Road (West)	40.4	45.6	43.0	48.9	40mph
Dane Hill Road (East)	42.4	48.5	45.0	51.5	
B1085	48.0	55.3	51.0	58.2	40mph
Elms Road (North)	48.9	57.6	46.6	55.3	40mph
Elms Road (South)	40.7	47.7	38.6	45.7	
Newmarket Road (Worlington)	45.2	50.9	45.7	51.7	40mph
B1102 Freckenham Road	49.6	57.2	49.6	57.6	-
Isleham Road	42.6	49.2	47.5	55.5	-
Newmarket Road (between A11 & Golf Links Road)	22.3	25.3	24.8	28.1	-

6.2.3 The temporary speed limits are proposed to be enforced through the Police, as would be the case for other permanent and temporary speed limits. However, given the recorded existing vehicle speeds, the proposed signage strategy, the presence of HGVs and the physical temporary traffic signals which would slow vehicles down to navigate through, it is expected that speeding would not be an issue through these temporary and short (in terms of distance) speed limit reductions.

6.3 Temporary Road and PRow Closures

6.3.1 Several roads are crossed, which will result in temporary road closures, by the Grid Connection Routes A and B, and internal cable crossings within the Sites. The temporary road closures include the following:

- Newnham Drove;
- Little Fen Road;
- First Drove;
- Broads Road;
- Chippenham Road;
- La Hogue Road;
- B1085;

² The requirement for temporary speed limit reduction and temporary traffic signals has been removed due to the removal from the Application of Sunnica West Site B.

- Elms Road;
- Beck Road;
- Isleham Road;
- B1102 Freckenham Road;
- Newmarket Road between (Worlington and Red Lodge); and
- U6006.

- 6.3.2 Each of the temporary road closures are expected to be no longer than one-week and occur on narrow roads where the use of two-way signals is not possible. Wherever possible, emergency vehicles, pedestrians and cyclists will be permitted to travel in both directions through the road closure.
- 6.3.3 Prior to any road closures advanced warning will be provided in line with the Local Highway Authority (LHA) guidance with diversions in place.
- 6.3.4 Over the course of the construction period a number of PRow may need to be temporarily closed for a maximum of three weeks. This is a worst-case scenario. Through discussions with the Local Highway Authorities, it is understood that their preference is to avoid PRow closures where they are required for vehicles to cross the PRow, with the preferred method to be the use of marshals (banksman/banks person) to enable usage of the PRow to cross the point at which the management is required. Other solutions may include diversion within the Order limits, where space allows. This is supported by the Applicant, however, the contractor will make the final decision as to whether marshals (banksman/banks person) can be used, and this will be decided on a case-by-case basis based on health and safety of workers and users of the public rights of way. PRow will only be closed temporarily in the event of there being no reasonable alternative to closure that would enable the works to be carried out safely and expeditiously within the limits of deviation for that work. . The Scheme has been designed to minimise the PRow closures in terms of the number of closures and their duration. The local highway authority will be consulted on PRow management or closures in accordance with the provisions of article 11 of the DCO.
- 6.3.5 Three PRow are located within the boundary of Sunnica East Site A. PRow W-257/007/0, W-257/002/X and W-257/002/0 cross the south-west part of the site between Beck Road and Mortimer Lane.
- 6.3.6 One PRow is located within the boundary of Sunnica East Site B. PRow W257/003/0 runs along the south-western boundary of the site from Turnpike Road at Red Lodge in the south-east to Badlingham Manor in the north-west. An unclassified road (U6006), which is a publicly accessible route, including for equestrians, extends northwards from Elms Road to Worlington. To the west of Sunnica East Site B the B1102 provides a footway for a section along the northern carriageway, alongside vehicles travelling eastbound, which is approximately 2m wide between North Street and East View. To the north, on Newmarket Road, footways are provided on both sides of the carriageway between the B1102 and The Paddocks.
- 6.3.7 Grid Connection Route A crosses the Chippenham footpath 49/7 before passing approximately 20m west of the Chippenham Gravel Pit CWS and crossing the

B1085. No PRowS are situated within the boundary of Sunnica West Site A. Snailwell 5 bridleway (PRow) runs along the south-west boundary of Sunnica West Site A.

6.3.8 There are six PRowS that intersect Grid Connection Route B. Towards Snailwell, footpath PRow 204/1 connects Snailwell with Chippenham Park. Footpath 92/19 runs through agricultural fields between Fordham and Snailwell. Footpaths 35/10 and 35/11 run between Wicken and Burwell passing through several agricultural fields. There are also two PRowS 35/6 and 35/7 running between Burwell and Reach, again through agricultural land.

6.3.9 The PRowS to be closed are as follows:

- W-257/002/X;
- W-257/007/0;
- W-257/003/0;
- W-257/002/0;
- 49/7;
- 204/1;
- 92/19; and
- 35/10.

6.3.10 The contractor will provide its proposed programme of proposed temporary closures of PRow to the relevant LHA. Appropriate signage relating to any temporary closures of the PRow, will be provided and agreed with the local highway authority as part of the approval of the CTMP. Signage will be provided at locations where an informed decision can be made by NMUs about utilising a different route..

6.4 Summary of Temporary Traffic Signals and Temporary Speed Limits

6.4.1 The proposed temporary speed limits and temporary traffic signals locations are outlined below:

- Proposed temporary traffic signals at the site access on Weirs Drove;
- Proposed speed limit reduction to 40mph along a short section of the B1102 Ness Road with temporary traffic signals at the site access;
- Proposed speed limit reduction to 40mph along a short section of Newmarket Road (north of the A142 roundabout) with temporary traffic signals at the site access;
- Proposed temporary traffic signals along a short section of Newmarket Road (north of the A142 roundabout);
- Proposed speed limit reduction to 40mph along a short section of Chippenham Road with temporary traffic signals at the site accesses;
- Proposed speed limit reduction to 40mph along a short section of La Hogue Road with temporary traffic signals at the site access;
- Proposed speed limit reduction to 40mph along a short section of the B1085 with temporary traffic signals at the site access;
- Proposed speed limit reduction to 40mph along a short section of Dane Hill Road with temporary traffic signals at the site access;
- Proposed speed limit reduction to 30mph along a short section of Elms Road with temporary traffic signals at the site access;
- Proposed temporary traffic signals along a short section of the B1102 Freckenham Road at the site access; and
- Proposed speed limit reduction to 40mph along a short section of Newmarket Road (Worlington) with temporary traffic signals at the site accesses.

6.4.2 The signage and layout of temporary traffic regulation measures will be agreed with the relevant County Authority in advance of implementation.

7 Management

7.1 Introduction

7.1.1 This section of the Framework CTMP and TP outlines the construction traffic and travel plan management measures that would be developed and detailed in the final CTMP and TP to be implemented.

7.2 Management Measures and Controls

HGV Measures and Controls

7.2.1 The freight strategy for the Sunnica Energy Farm seeks to manage HGV deliveries to the Order limits through the implementation of the following measures:

- Delivery Management System;
- HGV Routes;
- HGV Timing Restrictions;
- HGV Emission Standards;
- Communications Strategy;
- Site Accesses;
- Cranes and AILs Management Measures; and
- Cap on HGV deliveries at accesses

Delivery Management System (DMS)

7.2.2 A DMS will be implemented to control bookings of HGV deliveries from the start of the construction period. This will be used to effectively plan all HGV deliveries in accordance with the construction programme, regulate the flow of HGVs via timed delivery slots and monitor compliance of HGV routeing.

7.2.3 A Traffic Management and Monitoring System (TMMS) will be developed. The TMMS will provide details of the technologies and other means employed to monitor HGVs to/from the development site (e.g. Global Positioning System (GPS), Automatic Number Plate Recognition (ANPR)). This will enable the Applicant to monitor the following:

- Compliance with the HGV routes;
- Compliance with the number of HGV limits in terms of number of deliveries arriving and departing at any one time and over the course of the day; and
- Compliance with the timing restrictions.

7.2.4 The precise form of DMS would be determined following the appointment of a contractor and will include a summary of the contractual requirements which those visiting the site will have to adhere, along with the measures to be taken for non-compliance. This could include implementing a three-strike system for contractors which could lead to financial penalties. Details of the DMS will be included in the Final CTMP for approval by the LHAs.

HGV Routes

- 7.2.5 HGVs travelling to the Order limits from the wider highway network will be required to comply with the HGV routes set out in Section 4 of this document, and in accordance with the DMS and TMMS. An appropriate HGV signage strategy will be developed by the Applicant, agreed with the LHAs, and implemented by the Applicant, with the aim of ensuring compliance with agreed HGV routes. It is acknowledged that there will be the requirement for the occasional HGV to travel on the local highway network to access the secondary access points. Local HGV deliveries, those HGV movements where both the origin and the destination are within the Sunnica sites, would be required where possible to follow Sunnica HGV routes.
- 7.2.6 Contractor vehicles will be expected to comply with signed diversions in the event of traffic restrictions on HGV routes, including on the Local Highway Network and Strategic Road Network. This will be monitored and reported by the Applicant as part of compliance with HGV routes.

HGV Timing Restrictions

- 7.2.7 To reduce the potential impact of the HGV deliveries, the arrival and departure times will be managed to minimise the number of HGVs travelling to and from the site during the highway peak hours.. The HGV deliveries will be routed onto the SRN (A11 / A14) to travel to / from the site.
- 7.2.8 As set out in Section 4 of this document, the HGV deliveries will be required to use the A11 to travel to the main accesses of the Sites and will therefore have minimal impact on Snailwell (as the Change Report 2 January 2023 removes the requirement for HGVs to travel through Snailwell) and Worlington (associated with Sunnica East Site A) with other local villages near the Order limits such as Chippenham and Red Lodge avoided.
- 7.2.9 The timing restrictions are:
- No arrivals or departures on a Weekday between 08:00 and 09:00, and between 17:00 and 18:00;
 - No arrivals or departures on a weekday before 07:00 or after 19:00;
 - No arrivals or departures on a Saturday before 08:00 or after 13:00; and
 - No arrivals or departures on Sundays or public holidays.
- 7.2.10 The restrictions imposed on deliveries by HGVs will be set out within the DMS and TMSS.

HGV Monitoring

- 7.2.11 The Applicant will implement a monitoring system whereby the route of all HGVs travelling to and from the site is recorded such that non-compliance with the CTMP can be identified and measures taken. The precise form this monitoring will take will be included within the final CTMP.
- 7.2.12 The Applicant is committed to undertaking robust data collection and a reporting mechanism to record collisions and near misses associated with construction traffic or on construction routes. This has been provided in response to the Local Impact

Report. If there is a pattern of incidents that is apparent from information collected then this will be reviewed in terms of understanding causality. Understanding the underlying cause of any road safety issues will inform the approach to their resolution. Where relevant and related to the Scheme, operational measures will be considered and introduced by the Applicant to reduce the likelihood of occurrence, e.g. driver training. The Applicant will raise and discuss any apparent road safety issues with the relevant local highway authority.

HGV Emissions

- 7.2.13 All HGVs routing to and from the development sites (with the exception of vehicles used for the transportation of AILs including cranes) will be required to be compliant with the latest emission standards at the time of construction. As a response to the Local Impact Report, clarification is provided that the HGVs will be compliant with 'EURO VI' emissions standards.

Communications Strategy

- 7.2.14 A Communications Strategy will be developed by the Applicant to ensure that all relevant measures are communicated between contractors. This would include an information pack setting out the contractual requirements.
- 7.2.15 Further to this, the Applicant will hold regular meetings with contractors to discuss HGV management, any issues that arise and any required remedial actions.
- 7.2.16 A Communications Strategy will be developed to ensure that the public are notified of construction scheduling including road or PRow closures, or works affecting PRow where movement will be controlled by marshalls, in advance. This will include notifying relevant parish councils in the area, PRow statutory user groups, and the Fordham (Cambs) Walking Group. Further details of mechanisms and communications channels will be included in the final CTMP/TP.

Highway Condition Survey

- 7.2.17 The Applicant will undertake highway condition surveys before, during and after the construction to identify any impacts which are a result of the development that need to be remediated. It is noted that the condition surveys include the PRow which are crossed during the construction period.
- 7.2.18 Where the pre-condition survey identifies that there would be a benefit to having appropriate measures in place to protect or maintain the road surface, to reduce the likelihood of damage caused by construction vehicles, the applicant will enter discussions with the LHA on this matter.

- 7.2.19 The CTMP will include the following:

- The roads and PRow to be included within the survey;
- Details of the methodology to be used, to include both visual and mechanical surveys using methods such as SCANNER and SCRIM;
- Timing of surveys; and
- Commitment to provide the pre-condition survey outputs to the LHAs, following their completion, together with details of proportionate and cost-

effective preventative measures to limit potential damage to the highway as a result of the construction of the Scheme, if such measures are considered to be beneficial through analysis of the of the pre-condition survey findings.

Site Accesses

- 7.2.20 Consideration has been given to the indicative layout of the site accesses to ensure the geometry can accommodate HGVs in Section 5 above and in **Annex C** of this report.
- 7.2.21 Hard standing surface will be provided at the site accesses which can accommodate the weight of the HGVs. Where there is existing hard standing surface provided at a site access, the contractor will be responsible for ensuring it can accommodate the weight of the HGVs.
- 7.2.22 The detailed design of the site accesses will include measures to minimise vehicles obstructing the public highway at the access points. This will include:
- Any gates required or currently in situ will be located sufficient distance into the site to ensure that HGVs can pull off the public highway fully without causing an obstruction. Gates will not open outwards from the site.
 - Internal layout will ensure that all HGVs access and egress the site in a forward gear, with any turning required to be accommodated on the site.
 - Deliveries will be managed to avoid entering and exiting vehicles meeting at an access point. In the unlikely event that this occurs, the entering vehicle will have priority, and the internal site layout will be designed to ensure that there is sufficient space for the exiting vehicle to wait within the site and allow the entering vehicle to pass without obstruction. Sufficient forward visibility will be provided to enable this to take place safely.
- 7.2.23 In addition, wheel washing facilities will be provided at the site accesses to prevent mud being trafficked onto the highway.

Crane and AILs

- 7.2.24 Before the movement of the cranes and AILs the police will be given advanced notification in accordance with the Road Vehicle Authorisation of Special Types Order 2003.
- 7.2.25 In addition, communication and coordination will occur with National Highways and the local highway authority(ies) before the crane and AILs are required on-site to ensure sufficient notification is provided. This also includes the co-ordination of the temporary removal and subsequent re-instatement of signage and street furniture.
- 7.2.26
- 7.2.27 The transportation of abnormal loads and AILs will be undertaken in line with the Government and the local highway authority's guidance, and that timely applications will be made. Advance notice will be given to the Department for Transport, National Highways, the relevant highway authorities, the police and bridge owners as necessary in line with the requirements depending on the vehicles' weight, width and length which applies to abnormal loads and AILs.

Cap on HGV deliveries

- 7.2.28 The measures to manage HGV trips above are necessarily outline measures with detail to be defined when more information on the origins of deliveries are known. This is typical of a Framework Construction Traffic Management Plan at this stage of the planning process. To ensure the ultimate effectiveness of the Final Construction Traffic Management Plan, and to provide additional confidence to the Highways Authorities, a cap on HGV delivery numbers will be applied and monitored. This will ensure that the level of HGV traffic generated does not exceed that assessed within **Chapter 13: Transport and Access** of the Environmental Statement **[APP-045]**.
- 7.2.29 The Applicant proposes that a cap on HGVs will be implemented at the site access points during the construction period. Compliance with the HGV routes to/from each access will ensure that flows on each link do not exceed the levels set out in the ES. The table below presents the cap, which equates to the daily maximum number of HGV deliveries (single direction) forecast to go to each Sunnica access point during the construction period. The relevant local highway authority may approve a variation to the HGV cap proposed below and included in the CTMP if the relevant local highway authority is satisfied that to do so would not result in materially new or materially different environmental effects from those assessed in the Environmental Statement.

Table 7-1: Proposed HGV Cap

Site Access	HGV Daily Max Assessed (Number of Deliveries, single-direction movement)
Elms Road Sunnica East Site B (Access SE-A, SE-B and SE-C)	22
Newmarket Road Sunnica East Site B (Access SE-D and SE-H)	12
Ferry Lane Sunnica East Site A (Access SE-E)	17
Beck Road Sunnica East Site A (Access SE-F)	14
Newmarket Road between A11 & Golf Links Road Sunnica East Site B (Access SE-I)	12
La Hogue Road Sunnica West Site A (Access SW-A) and Chippenham Road Sunnica West Site A (Access SW-B)	48
Dane Hill Road Sunnica West Site A (Access SW-C)	17
Weirs Drove Burwell National Grid Substation Extension (Access CR-A)	9
Grid Connection Route A and B. Total daily cap across the route (not "per access")	23

Staff Vehicle Measures and Controls

- 7.2.30 The staff strategy for the Sunnica Energy Farm seeks to manage staff movements to and around the Order limits through the implementation of the following measures:
- Lift-Sharing;
 - Staff Routeing;

- Staff Arrival and Departure Times;
- Car parking strategy and parking permit scheme;
- Mini-Bus; and
- Cap on Vehicle Numbers.

Lift-sharing

- 7.2.31 To reduce the potential impact of vehicles associated with the staff during the construction period, the applicant will implement measures to maximise the numbers of staff that lift share with colleagues to reduce the number of vehicles travelling to/from the Site each day. Staff will also be directed to use strategic roads in the vicinity of the Site such as the A11, A14 and A142 to travel to/from the Site where appropriate to minimise the amount of construction traffic using local roads through the nearby villages, in line with the routes identified in Section 4 of this document for the HGVs.
- 7.2.32 To not exceed the staff vehicle forecast within **Chapter 13: Transport and Access** of the Environmental Statement [**APP-045**] and the Transport Assessment (**Appendix 13B** of the Environmental Statement [**APP-117**]), the average vehicle occupancy of 1.5 persons per vehicle, or equivalent measures limiting the total numbers of vehicles, will be required to be achieved at the peak construction period, with lift sharing to be encouraged throughout the whole construction period. To further reduce the impact of the development on the highways network throughout the construction period, the promotion to staff of the benefits of car sharing will be carried out such as reduced fuel costs, ease of parking with possibility of dedicated spaces for those sharing provided nearer to the mini-bus collection points within the compounds.
- 7.2.33 Further to the above, a Car Share Scheme will be implemented which will actively match potential sharers and be available to staff so that they can find their own match as well as that identified by the Transport coordinator. Further information regarding the Transport coordinator is provided in the 'management structure' section later on in this Framework CTMP and TP.
- 7.2.34 Dedicated spaces for those lift sharing will be considered within the parking areas and be located close to the mini-bus pick up points to reduce park and walk time. Further details on this will be provided in the full CTMP and TP once the contractor has been appointed.

Staff Routeing

- 7.2.35 Staff will be directed to use strategic routes for as much of their journey to and from the two centralised car parks as practicable. As well as the A11 and A14 this will include the A142 to avoid staff travelling through local villages. The routeing staff will be directed to use is the same identified for the HGV routes. The full CTMP and TP will contain details as to the measures to be employed to direct staff trips to these routes, to include on-street signage to be agreed with the LHAs.

Staff Arrival and Departure Times

- 7.2.36 The working hours of the staff are 07:00-19:00 with the AM development peak hour between 06:00 and 07:00 and the PM development peak hour between 19:00 and

20:00 for staff. The working hours ensure staff do not travel within the AM and PM highway peak hours 08:00-09:00 and 17:00-18:00. This will be monitored, reported and enforced as part of this CTMP.

Parking Strategy

7.2.37 The parking strategy seeks to minimise the potential impact of the vehicle trips associated with the staff, in particular in the surrounding villages. Two evenly split centralised car parking areas are proposed, one within Sunnica West Site A and the other in Sunnica East Site B. The alternative was to provide car parking compound at each of the site accesses / construction zones for staff to park in however this was considered likely to result in many staff trips on the local highway network. Therefore, the two centralised car parks were identified as the following:

- Sunnica West Site A – to be accessed off La Hogue Road which links to the A11 junction; and
- Sunnica East Site B – to be accessed off Elms Road which links to the A11 northbound off-slip and is also in close proximity to the Red Lodge Dumbbell Roundabouts providing access to/from the A11.

7.2.38 It is anticipated that a one-way system will be in place within the two car parks with a single point providing the entry/egress onto the local highway network. Appropriate signage, internally and externally, will identify the entry and egress routes for vehicles for the two car parking areas.

7.2.39 A car parking permit system is proposed to be implemented across the two car parking areas. The intention of the car parking permit system is to identify the most appropriate of the two car parks to direct staff to use strategic roads in the vicinity of the Site such as the A11 and A14 and also the A142. This will assist in minimising the number of vehicle trips which could occur on the local roads, in particular through Fordham, Chippenham, Worlington and Red Lodge. Any permit checking of staff vehicles on entry will occur within the site, after the vehicle has travelled along the internal haul road, at the entry to the car park itself, and will not involve staff queuing on public highway to access the site. Full details of the car parking permit system will be provided in the final CTMP and TP.

Mini-Bus

7.2.40 A mini-bus service will be used to transport staff around the site making use of internal routes where possible. Where the mini-bus is unable to use internal routes, the local highway network will be used to transport staff to the other site compounds. Considering the start/finish time of staff, any mini-bus service trips on the local highway network are expected to occur outside of the peak highway hours. Given the use of a mini-bus service the departure of staff is expected to be staggered outside of the highway peak hours and will be dictated on when staff return to the main two car parking areas.

7.2.41 Once staff origin locations are known investigation will be made into providing a mini-bus service to local residential areas to pick up/drop off staff who live locally. In addition, this will investigate the potential to provide the mini-bus service to local railway stations.

Cap on Construction staff vehicle numbers

- 7.2.42 The measures to reduce vehicle trips above are necessarily outline measures with detail to be defined when more information on workforce locations is known. This is typical of a Framework Travel Plan at this stage of the planning process. To ensure the ultimate effectiveness of the Final Travel Plan, and to provide additional confidence to the Highways Authorities, a cap on construction staff vehicle numbers will be applied and monitored. This will ensure that the level of traffic generated does not exceed that assessed within **Chapter 13: Transport and Access** of the Environmental Statement [APP-045].
- 7.2.43 The Applicant has demonstrated that an average occupancy of 1.5 persons per vehicle would not result in a significant effect in EIA terms, and therefore it is proposed to establish a daily vehicle cap at this level, which is 562 staff vehicles for Sunnica East, 522 staff vehicles for West and 937 staff vehicles across the scheme. These caps are for the development peak hours, i.e. the inbound movement per day between 06:00 to 07:00 and the outbound movement between 19:00 to 20:00. The working hours ensure staff do not travel within the AM and PM highway peak hours 08:00-09:00 and 17:00-18:00. This will be monitored, reported and enforced as part of this CTMP.

7.3 Management Structure

- 7.3.1 The overall management and implementation of the CTMP will be the responsibility of the Applicant. A Transport / Travel Plan coordinator will be appointed by the Applicant to be responsible for the management, development and implementation of the CTMP. Paragraph 7.3.2 below has been updated in relation to examination question Q1.10.64 to provide further clarification.
- 7.3.2 The Transport / Travel Plan coordinator will:
- Liaise proactively as appropriate with local transport and traffic groups, Fordham (Cambs) Walking Group, local planning authorities, local highway authorities, National Highways, the police, Parish Councils, the public, and the East of England Ambulance Service NHS Trust (EEAST). To include recording and collating any complaints relating to transport aspects of construction activities, and notification of road or PRow closures or works affecting PRowS where safe passage of NMUs will be facilitated by marshalls or other management measures;
 - Monitor the CTMP and TP to identify what is working well and what can be improved;
 - Promote the CTMP and TP to all staff and contractors travelling to and from the site to ensure compliance with its contents;
 - Monitor data relating to HGV routes, timing of HGV arrivals and departures, how contractors are utilising the DMS and the emission standards of vehicles;
 - Monitor data relating to HGV deliveries at each access point and compliance with the caps established within this CTMP, and introduce measures to ensure compliance with caps if necessary;

- Monitor data relating to levels of staff vehicles using each car park, compliance with established caps on vehicle numbers, and introduce measures to ensure that it remains below the established caps;
- Monitor data on road safety, including collisions and near misses, liaise with the LHAs and introduce measures to manage road safety risk where appropriate;
- Be responsible for carrying out the reporting processes as set out within this CTMP/TP;
- Be responsible for initiating the enforcement process if monitoring and reporting identifies a breach requiring enforcement. This is likely to involve escalating the matter to a senior member of staff and providing them with the required information to take appropriate action as agreed with the LHAs through the final CTMP;
- Manage the Car Share Scheme;
- Investigate providing a mini-bus service to local railway stations and local residential areas to pick-up and drop-off staff;
- Assign staff to the most appropriate of the two centralised car parks including the provision of a car parking permit to staff for one of the two centralised car parks; and
- Discuss issues which come to light with the relevant parties and discuss any amendments required to ensure that compliance with the CTMP and TP is maintained.

7.4 Monitoring and Review

HGVs

- 7.4.1 To ensure that contractors are complying with the CTMP and TP, a monitoring and review approach will be taken. This will be led by the Transport coordinator.
- 7.4.2 The Transport coordinator will monitor data relating to compliance with the caps on HGV deliveries at each access, the routes utilised, the timing of arrivals and departures, how contractors are utilising the DMS, the emission standards of vehicles accessing the site, road safety, including collisions and near misses, and reports from external parties including the public. Regular reporting will be on an initial monthly basis however the regularity of reporting will be reviewed as the construction progresses and the reporting frequency is likely to be lowered in agreement with the LHAs once the peak construction month (nine) has passed. The reporting will set out the results of the data monitoring and identify any issues which need to be resolved and what measures would need to be implemented to ensure that any identified issues do not occur again.

Staff

- 7.4.3 The Car Share Scheme will be managed by the Transport coordinator to implement and identify potential matches for car sharers. This will also be available to staff so that they can find their own matches. The Transport coordinator will require the starting location of staff before commencing work on site, to assist in promoting the Car Share Scheme and also to allocate car drivers to one of the two car parking areas which will be based on their starting location for their travel to the Site. This takes into consideration if staff are starting their journey from a different location to their home. Where possible, staff's primary working location in the Sunnica East Site and Sunnica West Site will be the same as their parking permit location.
- 7.4.4 The two centralised car parks will be monitored during the arrival of staff in the morning and departure of staff in the evening. Given the close proximity of the two centralised car parks to the A11, the majority of staff will travel northbound on La Hogue Road and Elms Road to access the Sunnica West and East car parks respectively. Monitoring will be in place to ensure a low number of staff travel southbound (i.e. arrive via the north) on La Hogue Road and Elms Road. The monitoring will also include that the majority of staff departure southbound on La Hogue Road and Elms Road in the PM development peak hour.
- 7.4.5 During arrival of staff at both sites the car parking areas will be managed to ensure the efficient arrival of staff and assignment of the car parking spaces where vehicles will be routed to the most appropriate location based on their arrival time. The car parking management will ensure staff entering the car parking areas park in a timely and safe manner. Given the working patterns identified it is not expected there will be the requirements for car parking management outside of the development peak hours of 06:00-07:00 and 19:00-20:00.
- 7.4.6 The Applicant proposes to introduce a cap on vehicle numbers using each of the staff car parks in line with the peak number of staff vehicles forecast in the Transport Assessment [APP-117], to provide a level of control against potential uncertainty, and surety that the measures in the Final Travel Plan are effective. The caps on vehicle numbers for each of the car parks and the scheme as a whole are set out in

paragraph 7.2.43. Monitoring will be undertaken by way of In/Out counts at the two car park accesses. The exact method will be determined by the contractor at the time of the construction. As a minimum, data will be collected on a weekly basis, although it is likely that it will be collected continuously using automated technology. The Travel Plan Co-ordinator will monitor data against the construction programme and take early action to introduce measures if vehicle numbers are forecast to exceed the cap.

7.4.7 Further clarification is provided below in response to the Local Impact Report regarding Travel Plan Reporting. The Applicant is committed to regular and frequent monitoring on a monthly basis, or such lesser frequency as is agreed with the LHAs. This will include the following information, to be provided to the LHAs:

- Progress of the project against specific gateways;
- Freight movement to/from the site (routeing, timing and total daily numbers at specific access points, including compliance with established caps);
- Details of non-compliance with routing or speed limits;
- Near misses or safety related incidents;
- Freight compliance with appropriate exhaust emissions (Euro VI);
- Transport of AILs to/from the site (routeing, timing, classification);
- LGV movements to/from the site;
- Staff movement to/from the site, based on total numbers of vehicles and compliance with shift patterns, to include any movements outside of shift times;
- Car park occupancy based on In/Out counts used to monitor the staff vehicle cap;
- Information on complaints received on transport related issues including parking; and
- Notification of any breaches of the CTMP or TP, as soon as reasonably possible.

8 Compliance and Enforcement

8.1 Introduction

8.1.1 This section of the Framework CTMP and TP provides a summary of the mechanisms that will ensure compliance with the final CTMP and TP.

8.2 Compliance

8.2.1 There are three areas under which enforcement of the CTMP and TP will be imposed: Best Practice, Contractual Conditions and Default Mechanisms.

Best Practice

8.2.2 The Applicant will use internal management procedures to ensure compliance with the requirements of the CTMP and TP, including:

Contractor kick off meetings:

- Contractors will be reminded of the Applicant's standards and expectations as set out in contract documentation.

Site induction:

- Driver induction to include briefing on aims and objectives of the CTMP and TP, including booking system, designated routes and driver behaviour.
- A copy of the CTMP and TP will be provided to each of the companies who provide services to the Scheme so that all are informed of how the sites are being managed and what the Applicant expects all contractors to adhere to.

Reporting:

- Incidences of non-compliance with the CTMP and TP will be investigated.
- Reports from each incident will be raised and shared with the relevant contractor.
- Where appropriate updates to the CTMP and TP will be considered, in accordance with the provisions of the DCO, to resolve the risk of repeated breaches.

Contractual Conditions

8.2.3 Upon appointment, each contractor will be provided with a contract setting out their contractual requirements in terms of compliance with the CTMP and TP.

8.2.4 A copy of the CTMP and TP will be provided along with confirmation of the routes vehicles are required to take to reach the site from their starting location as well as the access which they will use and the time of entry

Enforcement

8.2.5 If despite the careful efforts of the Applicant and its contractor, there are breaches of the movement arrangements as set out in this CTMP during the construction phase, the enforcement procedures are as follows.

- The Transport coordinator will notify the Applicant of a breach of the CTMP or TP arrangements as and when they occur.
- The Applicant will issue a warning letter to the relevant contractor outlining what action would be taken in the event of a further breach. Details relating to the action which would be taken will be provided within the full CTMP and TP.
- The Applicant will report the details of the response to the Transport coordinator as part of the monitoring report. The monitoring report will be made available to the relevant local planning authorities and relevant highway authorities at their request to ensure compliance and that action is being taken where breaches are occurring.

8.2.6 Further detail on the sanctions which could be applied would be included within the final CTMP and TP. This would include an appropriate process to ensure that breaches are addressed, and measures are put in place to limit the risk of, and enforce against, repeated breaches. An example of what is meant by such a process is as follows:

- Stage One – the highway authority confirms a breach and requests the Transport Coordinator to review the data and concerns. The highway authority and the Transport Coordinator would then agree the extent of the breach of controls and agree action. This is likely to be a contractor warning at this stage;
- Stage Two – If a further material breach is identified the contractor would be given a further warning and required to produce an action plan to outline how the issue would be rectified and any additional mitigation measures proposed; and
- Stage Three – Should further breaches still occur the contractor would be required to remove the offender from the site and the contractor/ supplier would receive a formal warning. Any continued breaches by individuals of the supplier/ contractor may be dealt with by the formal dispute procedures of the contract.

Annex A – Figures

Annex B – SCC Lorry Route Map and CCC Advisory Freight Map

Annex C – Site Access Drawings

Annex D – Crane and AIL Routes Review Drawings

Annex E – Stage 1 Road Safety Audit

Annex F – Speed Surveys

Annex G – 46.63m AIL Report